

Why are there so many insect species? Perspectives from fossils and phylogenies

Peter J. Mayhew*

Department of Biology (Area 18), University of York, PO Box 373, York, YO10 5YW, UK

(Received 28 September 2006; revised 11 April 2007; accepted 2 May 2007)

ABSTRACT

Over half of all described species are insects, but until recently our understanding of the reasons for this diversity was based on very little macroevolutionary evidence. Here I summarize the hypotheses that have been posed, tests of these hypotheses and their results, and hence identify gaps in knowledge for future researchers to pursue. I focus on inferences from the following sources: (i) the fossil record, normally at family level, and (ii) insect phylogenies, sometimes combined with: (iii) the species richness of insect higher taxa, and (iv) current extinction risks.

There is evidence that the species richness of insects has been enhanced by: (i) their relative age, giving time for diversification to take place; (ii) low extinction rates. There is little evidence that rates of origination have generally been high or that there are limits on numbers of species. However, the evidence on macroevolutionary rates is not yet so extensive or coherent as to present unequivocal messages.

As regards morphological, ecological, or behavioural hypotheses, there is evidence that diversity has been enhanced by (iii) flight or properties resulting from it like enhanced dispersal, (iv) wing folding, and (v) complete metamorphosis. However, in all these cases the evidence is somewhat equivocal, either because of statistical issues or because evidence from different sources is conflicting.

There is extensive evidence that diversity is affected by (vi) the ecological niche. Comparative studies indicate that phytophagy generally increases net diversification rates, and reduces extinction risk. However, niche specialization is also associated with an increase in extinction risk. Small body size (vii) is often associated with low extinction risk in comparative studies, but as yet there is no solid evidence that it consistently enhances net rates of diversification. Mouthpart diversity (viii) has generally increased over time in the insects, but cannot explain the apparent great increase in diversity seen in the Cretaceous and Tertiary. Sexual selection and sexual conflict (ix) are two processes that are widespread in insects, and there is comparative evidence linking both to increased diversification. Although some comparative evidence links tropical distributions (x) to increased rates of diversification, the extent to which latitudinal richness gradients are unusual in insects is equivocal.

There is little to no direct evidence from fossils and phylogenies that insect diversity has generally been affected by (i) sensory- or neuro-sophistication, (ii) population size or density, (iii) generation time or fecundity, (iv) the presence of an exoskeleton or cuticle, (v) segmentation or appendage diversity, (vi) adaptability or genetic versatility, though all of these remain plausible hypotheses awaiting further tests. The data suggest that the insect body ground plan itself had no direct effect on insect diversity.

Thus, whilst studies to date have given substantial understanding, substantial gaps still remain. Future challenges include: (i) interpreting conflicting messages from different sources of data; (ii) rating the importance of different hypotheses that are statistically supported; (iii) linking specific proximate to specific ultimate explanations and *vice versa*; and (iv) understanding how different ultimate hypotheses might be dependent on each other.

Key words: co-evolution, dispersal evolution, diversity, extinction, flight, herbivory, macroevolution, phytophagy, speciation, species richness.

* Address for correspondence: Tel: +44 (0)1904 328644; Fax: +44 (0)1904 328505, E-mail: pjm19@york.ac.uk

CONTENTS

I. Introduction	426
II. Current hypotheses	430
III. What we know	431
(1) Proximate variables	431
(a) Time	431
(b) Net rates of cladogenesis	431
(c) Speciation/origination rates	432
(d) Extinction rates	432
(e) Evidence for limits to species richness	435
(2) Ultimate variables – morphology	435
(a) Insect body ground plan	435
(b) Flight/wings/dispersal	436
(c) Folding wings	437
(d) Complete metamorphosis	438
(e) Mouthparts	438
(f) Exoskeleton/cuticle, segmentation, appendages and eggs	438
(g) Sensory and neurosophistication	441
(h) Small body size	441
(3) Ultimate variables – ecology and behaviour	442
(a) Interspecific interactions and specialization	442
(b) Sexual selection and sexual conflict	444
(c) Tropical distribution	445
(d) Generation time and rates of increase	446
(e) Population size and density	446
(f) Adaptability	446
(4) Relative influence	446
(5) Combining and distinguishing ultimate variables	447
(6) Linking proximate and ultimate variables	448
(a) From proximate to ultimate	448
(b) From ultimate to proximate	448
(c) Reconciling the different approaches	448
IV. Future work	449
(1) New tests	449
(a) Proximate variables	449
(b) Ultimate variables	449
(2) New data	449
(a) Phylogeny	449
(b) Fossil data	449
(c) Extant species richness	450
(d) Current extinction risk	450
V. Conclusions	450
VI. Acknowledgements	450
VII. References	451

I. INTRODUCTION

Many of those with only a passing knowledge of biology are nonetheless aware that a large proportion, in fact over half, of all described species are insects (Fig. 1). With the acknowledgement of this diversity comes the issue of why it should be. The problem is, largely, a macroevolutionary one: what features of the biology of this group have promoted their present species richness? Historically our understanding of this question has been hindered by both the available data and methods. For this reason broad discussions of the topic have tended to stray little from the

hypothetical, and are concentrated in non-peer-reviewed literature such as entomology text books (Table 1).

Since the late 1980s important new macroevolutionary data and techniques have become widely available to test directly some of the hypotheses. This paper summarizes the progress that such studies have made so far, focusing on fossils and phylogenies, and identifies targets to increase our understanding of this fundamental property of the living world still further.

Whilst these recent studies have made useful progress in testing individual hypotheses, using their combined results to provide an overall answer to the title question is fraught

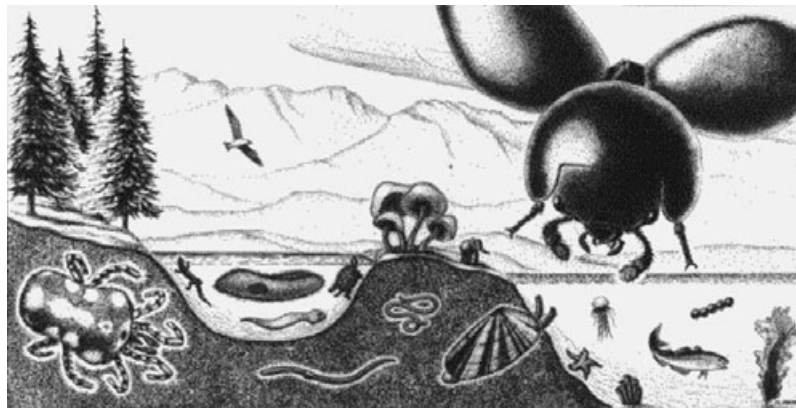

Fig. 1. A “species-scape” in which different taxa are scaled according to their described species richness. Here the flying beetle represents all hexapods, the pine trees all plants, and all vertebrate classes are also represented. Reprinted from Wheeler (1990) with kind permission from the Entomological Society of America.

with non-trivial problems which have barely begun to be addressed. These problems include: (i) interpreting conflicting messages from different sources of data; (ii) rating the importance of different hypotheses that are statistically supported; (iii) linking specific proximate to specific ultimate

explanations and *vice versa*; and (iv) understanding how different hypotheses might explain each other.

Whilst I show that the information from fossils and phylogenies is valuable for our current understanding of insect species richness, it is not the only source of

Table 1. Hypotheses on the reasons for the species richness of insects

Hypothesis	Possible mechanism	Reviews citing the hypothesis	Macroevolutionary studies providing relevant data or tests
Proximate variables			
Long time for diversification	Insects are an ancient group and have achieved a high species richness not through rapid speciation or low extinction rates but through sustained low rates of diversification	Grimaldi & Engel (2005); Gullan & Cranston (2005)	Labandeira & Sepkoski (1993); Jarzembowski & Ross (1996); Mayhew (2002, 2003)
High speciation rate	The high species richness of insects is primarily due to a high propensity to speciate	McGavin (2001); Grimaldi & Engel (2005)	Stanley (1979); Wilson (1983); Hey (1992); Labandeira & Sepkoski (1993); Jarzembowski & Ross (1996); Eble (1999); Ribera <i>et al.</i> (2001); Barraclough & Vogler (2002); Bokma (2003); Coyne & Orr (2004)
Low extinction rate	The high species richness of insects is primarily due to high probability of species persistence	Speight <i>et al.</i> (1999); McGavin (2001); Grimaldi & Engel (2005); Gullan & Cranston (2005)	Stanley (1979); Labandeira & Sepkoski (1993); Coope (1995); Mawdsley & Stork (1995); Thomas & Morris (1995); Hambler & Speight (1996); Jarzembowski & Ross (1996); Fagan <i>et al.</i> (2001); Bokma (2003); C. D. Thomas <i>et al.</i> (2004); J. A. Thomas <i>et al.</i> (2004); Dunn (2005)

Table 1 (cont.)

Hypothesis	Possible mechanism	Reviews citing the hypothesis	Macroevolutionary studies providing relevant data or tests
Carrying capacity	Small body size, ecological specialization, phytophagy or other important ecological niches, promoted by morphological innovations, makes any carrying capacity very high for insects	Not explicitly considered though Grimaldi & Engel (2005) and Gullan & Cranston (2005) both consider the importance of sustaining diversification	Hey (1992); Labandeira & Sepkoski (1993); Eble (1999); Ribera <i>et al.</i> (2001); Barraclough & Vogler (2002); de Queiroz (2002)
Ultimate variables Insect body ground plan	A number of modifications including external mouthparts and ovipositor that may have widened niche availability	Carpenter (1953); Romoser (1973); Evans (1984); Samways (2005)	Zeh <i>et al.</i> (1989); Mayhew (2002, 2003)
Flight/wings/dispersal	Increases dispersal ability, perhaps lowering extinction rate and increasing speciation rate, opens up new niche opportunities	Imms (1947); Carpenter (1953); Romoser (1973); Horn (1976); Evans (1984); Speight <i>et al.</i> (1999); McGavin (2001); Elzinga (2004); Grimaldi & Engel (2005); Gullan & Cranston (2005); Samways (2005)	Nieminen (1996); de Queiroz (1998); Thomas (2000); Ribera <i>et al.</i> (2001); Mayhew (2002, 2003); Kotze & O'Hara (2003); Kotiaho <i>et al.</i> (2005); Shahabuddin & Ponte (2005); Biesmeijer <i>et al.</i> (2006)
Folding wings	Enables flying insects to exploit concealed environments, raising speciation rates and raising macroevolutionary carrying capacities	Carpenter (1953); Romoser (1973); Evans (1984); Elzinga (2004)	Mayhew (2002, 2003)
Complete metamorphosis	Allows specialized juvenile and adult forms, increasing niche opportunities, and raising speciation rates or macroevolutionary carrying capacities	Carpenter (1953); Horn (1976); Romoser (1973); Evans (1984); Speight <i>et al.</i> (1999); Elzinga (2004); Grimaldi & Engel, (2005); Gullan & Cranston (2005)	Ross <i>et al.</i> (2000); Yang (2001); Mayhew (2002, 2003)
Mouthparts	Mouthparts are highly adaptable and can be modified and specialized to exploit a wide range of foods, increasing speciation rates or macroevolutionary carrying capacities	May (1978); Elzinga (2004); Samways (2005)	Labandeira & Sepkoski (1993); Labandeira (1997)
Segmentation and appendages	Modifiable into a variety of forms to exploit different ecological niches, raising speciation rates and macroevolutionary carrying capacities	Elzinga (2004); Grimaldi & Engel (2005)	Nee <i>et al.</i> (1996)
Exoskeleton/cuticle	Adaptable body parts, tolerate a variety of environments, increase niche width	Imms (1947); Horn (1976); McGavin (2001); Grimaldi & Engel (2005); Samways (2005)	Zeh <i>et al.</i> (1989); Nee <i>et al.</i> (1996)
Sensory and neurosophistication	Allows specialized behaviours that widen ecological opportunities and enhance speciation rates	McGavin (2001); Gullan & Cranston (2005)	De Queiroz (1999, 2002)

Table 1 (cont.)

Hypothesis	Possible mechanism	Reviews citing the hypothesis	Macroevolutionary studies providing relevant data or tests
Small size	Increases available niches to exploit, thus raising speciation rates and macroevolutionary carrying capacities. Fast generation times and higher population sizes lead to lower extinction rates (see below)	Imms (1947); Horn (1976); May (1978); McGavin (2001); Elzinga (2004); Gullan & Cranston (2005)	Kruess & Tscharnkte (1994, 2000); Nieminen (1996); Didham <i>et al.</i> (1998); Davies <i>et al.</i> (2000); Sullivan <i>et al.</i> (2000); Katzourakis <i>et al.</i> (2001); Orme <i>et al.</i> (2002); Misof (2002); Kotze & O'Hara (2003); K. F. Davies <i>et al.</i> (2004); Koh <i>et al.</i> (2004); Kotiaho <i>et al.</i> (2005); Shahabuddin & Ponte (2005); Benedick <i>et al.</i> (2006)
Interactions with other organisms, especially plants, and specialization	Large number of niches to exploit increases speciation rate or length of time over which speciation is unconstrained by logistic processes. Being at a low trophic level decreases extinction rates	Horn (1976); Speight <i>et al.</i> (1999); Resh & Cardé (2003); Grimaldi & Engel (2005); Gullan & Cranston (2005); Samways (2005)	Mitter <i>et al.</i> (1988); Labandeira & Sepkoski (1993); Wiegmann <i>et al.</i> (1993); Jarzembowski & Ross (1996); Nieminen (1996); Didham <i>et al.</i> (1998); Farrell (1998); Janz & Nylin (1998); Davies <i>et al.</i> (2000); Ross <i>et al.</i> (2000); Sullivan <i>et al.</i> (2000); Johnson & Clayton (2003); Kotze & O'Hara (2003); Krauss <i>et al.</i> (2003); K. F. Davies <i>et al.</i> (2004); Jackson (2004); Koh <i>et al.</i> (2004); Kotiaho <i>et al.</i> (2005); Benedick <i>et al.</i> (2006)
Sexual selection/sexual conflict	Factors affecting mating success hasten the rate of reproductive isolation, increasing speciation rates	Elzinga (2004); Gullan & Cranston (2005)	Arnquist <i>et al.</i> (2000); Katzourakis <i>et al.</i> (2001); Misof (2002); Koh <i>et al.</i> (2004)
Tropical distribution	Able to benefit from tropical effects on diversity	Gullan & Cranston (2005)	Cardillo (1999); Willig <i>et al.</i> (2003); Hillebrand (2004)
Short generation times, high rates of increase	Recover from disturbances, rapid exploitation of opportunities, high rates of evolution leading to low extinction rates and high speciation rates	May (1978); McGavin (2001); Elzinga (2004); Grimaldi & Engel (2005)	Katzourakis <i>et al.</i> (2001); Misof (2002); Biesmeijer <i>et al.</i> (2006)
Adaptability/genetic versatility	Can endure environmental change and exploit new opportunities quickly, thus raising speciation rates and lowering extinction rates, or raising macroevolutionary carrying capacities	Imms (1947); May (1978); Gullan & Cranston (2005); Samways (2005)	Zeh <i>et al.</i> (1989); Labandeira (1997)

information, and it can also be argued that on its own it cannot provide a complete story. To keep the scope of this review manageable I have deliberately avoided including several other relevant kinds of study, primary amongst which are those addressing the ecological determinants of

community richness, studies of rapid evolution, and mechanistic studies of speciation and extinction. Such studies are however valuable in motivating the work presented here, as well as providing the vital means to turn correlations into causative arguments.

II. CURRENT HYPOTHESES

Works that address the title question have collectively raised many different hypotheses (Table 1). These hypotheses may relate directly to cladogenetic variables and processes (which I call here proximate issues; Mayhew, 2006), as well as to the ecological variables and phenotypes that serve to alter them (ultimate issues; Mayhew, 2006) (Fig. 2). There is a large degree of overlap in the considered hypotheses, suggesting some degree of consensus amongst experts, at least in ideas.

I consider here four proximate macroevolutionary variables: (a) time (or clade age), (b) speciation rate, (c) extinction rate, and (d) limits to species richness or carrying capacity. Time is a necessary consideration in macroevolutionary issues, since we are interested in understanding the outcome of rates (Yule, 1924; Purvis, 1996; Coyne & Orr, 2004). The simplest (one parameter) model of clade growth is constant rate exponential growth without extinction, also known as the ‘‘Yule’’ or ‘‘pure birth’’ model (Yule, 1924; Raup *et al.*, 1973; Raup, 1985; Hey, 1992; Purvis, 1996; Mooers & Heard, 1997; Nee, 2001). Clades following such a model would show ever increasing growth (a and d in Fig. 3). Simply allowing extinction as well as speciation at constant rates does not substantially affect the major prediction of exponential growth: the difference between the speciation and extinction rate defines the net rate of cladogenesis, effectively a substitute for the speciation rate in the pure birth model. However, such a constant rate ‘‘birth-death’’ process can lead to fast early clade growth, measured as actual numbers of species present through time (c in Fig. 3) (Nee, May & Harvey, 1994; Harvey, May & Nee, 1994; Purvis, 1996; Mooers & Heard, 1997; Nee, 2001). For a given net rate of tree growth, a high extinction rate will imply a higher speciation rate to maintain the same net rate of cladogenesis. Adding a limit to species richness (carrying capacity) allows for logistic growth of the clade (Nee, Mooers & Harvey, 1992; Benton, 1997), where the net rate of cladogenesis reduces as species richness approaches the carrying capacity, leading to a leveling off of species richness (b, e in Fig. 3).

How can these four variables produce a high species richness? This may be attained in general by high speciation rates, and/or low extinction rates, together giving rise to

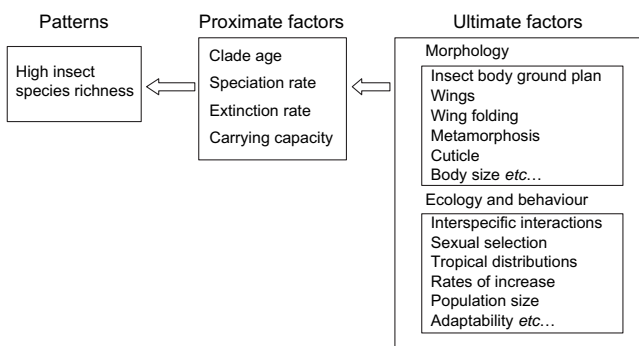

Fig. 2. The types of explanation for hexapod species richness and their interrelationships, as presented in this review.

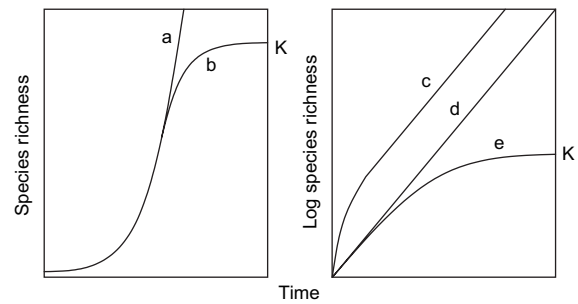

Fig. 3. Clade growth according to different hypothetical models, shown both with a linear and logged y-axis. Under a pure birth process, growth of the clade is exponential (a), giving a straight line on a logged y-scale (d). Clades showing a constant net rate of cladogenesis, but where both speciation and extinction occur, grow exponentially through most of their history at a rate determined by the difference between the speciation and extinction rates (c). However their growth rate is faster to begin with than in the pure birth model because species cannot go extinct until after they have formed, hence clade growth is initially unfettered by extinction (the ‘‘push of the past’’). Logistic growth introduces the idea of a limit to species richness (carrying capacity, K), with the net rate of cladogenesis declining as K is approached (b, e).

a high net rate of diversification. A higher limit on species numbers, for example because of a bigger area or availability of more niches, will obviously aid species richness (Fig. 3). Alternatively, a group might achieve high species richness by sustained diversification over a long period, albeit at a low rate.

Speciation and extinction rates and limits to species richness are themselves driven by other, ultimate variables that should be properties of insects, or a subgroup of insects (Table 1). Many of these are general morphological properties (small size, sensory or neuro-sophistication, segmentation, mouthparts). Some of them are candidate morphological key innovations (insect body ground plan, wings, folding wings, complete metamorphosis). Some are ecological properties (interactions with other organisms, and specialization, latitudinal distribution, fast generation times), and some behavioural (sexual selection). The mechanisms by which the ultimate processes drive the proximate processes are often not explicitly stated. For example, short generation times may help reduce extinction rates by allowing populations to recover rapidly from periods of disturbance. Alternatively they may enhance speciation rates by allowing populations rapidly to exploit new ecological opportunities.

Eventually one would hope to find ultimate explanations for proximate explanations and *vice versa*. A distinction needs to be drawn here between two subtly different interpretations of the title question. Perhaps the most intuitive interpretation is: ‘‘Why have insects diversified so much and not some other (non-insect) group?’’. However, another valid interpretation is: ‘‘Why have some kinds of insects diversified so much and not others?’’. Answers to the first question rely on comparisons among insects and non-insect taxa. If, however, you want an answer to the second kind of

question, you will rely on comparisons among different sub-taxa of insects. This distinction has interesting consequences: because they make use of different datasets, these two approaches can come to seemingly incompatible conclusions, especially when one attempts to draw links between proximate and ultimate forces (see below).

Macroevolutionary studies incorporating fossil or phylogenetic data have provided information, to differing extents, on all the proximate processes, and all of the 14 ultimate variables (Table 1). The next section outlines the tests that have been performed on these hypotheses and their findings.

III. WHAT WE KNOW

(1) Proximate variables

(a) Time

The hexapods are an ancient terrestrial group. The earliest known hexapods are from the Rhynie Chert of the lower Devonian (Pragian, 411–407 million years ago), one of the earliest terrestrial communities. They include a springtail (Collembola) *Rhyniella praecursor* (Whalley & Jarzembowski, 1981; Ross & York, 2004), as well as a possible pterygote *Rhyniognatha hirsti* (see Engel & Grimaldi, 2004; Ross & York, 2004) and a species, *Leverhulmia mariae*, that may share affinities with the Archaeognatha and Zygentoma (Fayers & Trewin, 2005). The true age of the hexapods (i.e. the age of their common ancestor with non-hexapod taxa) has been dated from phylogenies at about 660 million years (Pisani *et al.*, 2004) and 430 million years (Gaunt & Miles, 2002), but no fossil evidence exists beyond the above.

This age, combined with the exponential nature of species diversification, means that net rates of lineage splitting need not be especially high to achieve a large extant richness. Additionally, only small differences in net rates of lineage splitting are necessary over such time scales to effect very large changes in species richness. For example, two taxa radiating exponentially over 400 million years at the almost identical rates of 0.0288 million years⁻¹ and 0.0270 million years⁻¹, would produce 100,000 species in the first case, but only 50,000 species in the second case.

Nearly all the extant insect orders were in existence by the Permian (Jarzembowski & Ross, 1996), well before the Cretaceous angiosperm radiation and the Tertiary mammalian and bird radiations. However, whilst the extant angiosperm families had very largely originated by the Tertiary (T. J. Davies *et al.*, 2004), a great number of extant insect families are of Eocene and Oligocene origin, making them of similar age to extant mammalian and bird families (Jarzembowski & Ross, 1996) (Figs. 4, 5). The age of hexapod higher taxa makes it generally relevant to ask if there has been any logistic slow-down in hexapod radiation (see below).

(b) Net rates of cladogenesis

The net rate of cladogenesis of hexapods is easily estimated from their extant richness (Table 2) and the age of the earliest fossil. Mayhew (2002) estimated this as 0.0347

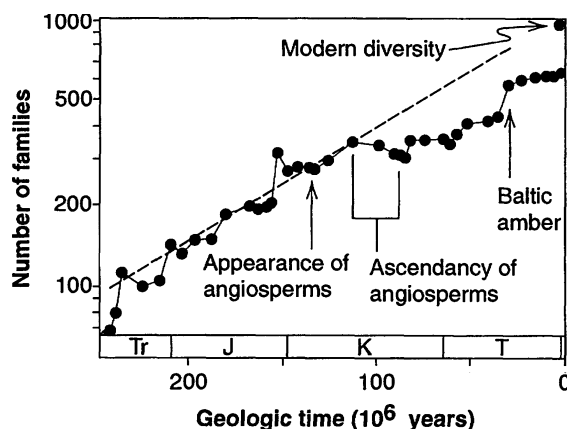

Fig. 4. The increase in the number of insect families in the fossil record, since the Permian mass extinction, on a logarithmic y -axis (compare with Fig. 3). Up to the mid-Cretaceous, insect clade growth was exponential. Thereafter, the curve is depressed somewhat from the exponential, suggesting that the number of families may be approaching a carrying capacity. Reprinted from Labandeira & Sepkoski (1993), with kind permission of the American Association for the Advancement of Science. Copyright 1993, AAAS.

million years⁻¹, using described species richness largely from Parker (1982). The variation around this number amongst extant orders ranges from 0.0135 to 0.0581 million years⁻¹. Bokma (2003) estimated the speciation and extinction rates of the hexapods by maximum likelihood, using data on their ordinal species richness and ages (Table 3), and the difference between these two rates is 0.026, of the same order of magnitude as the values above. By contrast, some estimates from more recently derived groups are much higher: they range from 0.025 million years⁻¹ for some Coleopteran families, to 1.25 million years⁻¹ which is one estimate for the Hawaiian *Drosophila* radiation (Coyne & Orr, 2004). However, rates of about 0.2 million years⁻¹ are reasonably common (e.g. Wilson, 1983; Hey, 1992; Barraclough & Vogler, 2002). Taking the most spectacular radiations: angiosperm-associated beetles within the Phytophaga (Farrell, 1998), values are pretty similar. The angiosperm-associated weevil clade has 44,000 spp. and is of early Jurassic origin, giving a value of about 0.06 million years⁻¹. The angiosperm-associated longhorn beetle clade is of late Cretaceous origin and has 25,000 spp., giving a value of about 0.150 million years⁻¹. Finally, the angiosperm-associated leaf-beetle clade contains about 33,400 spp. and is of mid-Jurassic origin, giving a value of about 0.06 million years⁻¹ (data from Farrell, 1998). Overall the data from insects are very similar to those for a range of other taxa, though rates may be higher than for a number of marine invertebrate groups (Stanley, 1979; Coyne & Orr, 2004).

Several studies of insect phylogenies have identified heterogeneity in net rates of cladogenesis amongst insect taxa (e.g. Guyer & Slowinski, 1991, 1993; Mayhew, 2002), and in addition some evidence indicates that rates are heritable within the insects (Savolainen *et al.*, 2002). This further indicates that key innovations are a likely ultimate

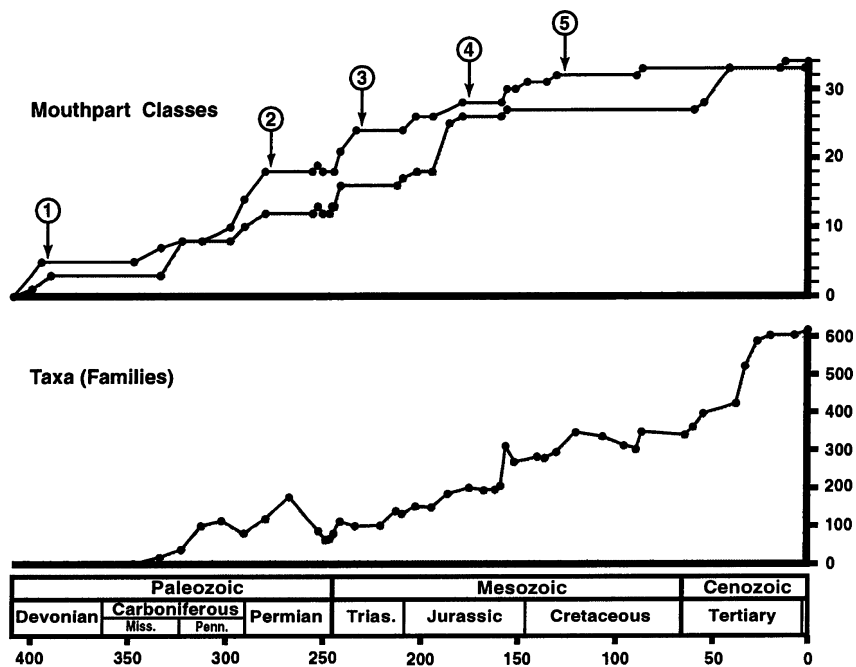

Fig. 5. Comparison of insect mouthpart diversity (upper panel) and family diversity (lower panel) over the fossil record. In the upper panel, the bottom curve and dark shading represents strong evidence for presence and the top curve less strong evidence. Numbered arrows represent equilibria following five phases in mouthpart diversification: 1, Early Devonian: primitive modes only. 2, Pennsylvanian innovations. 3, Early Permian innovations. 4, Late Triassic to Early Jurassic innovations. 5, Late Jurassic to early Cretaceous innovations. Reprinted, with permission, from Labandeira (1997), the Annual Review of Ecology and Systematics, Volume 28, © 1997 by Annual Reviews.

explanation for the species richness of the insects, and furthermore that it is not likely to be the species richness of insects *per se* that we must explain, but rather some subgroups of them. All these phenomena also make it plausible that the process of species selection (see Coyne & Orr, 2004) might have contributed to the species richness of insects.

(c) Speciation/origination rates

Bokma (2003) has estimated the speciation rates of the hexapods from the extant ordinal species richness and their ages using maximum likelihood (Table 3). When speciation and extinction rates are stochastic over time but the same across taxa, differences in taxon richness simply reflect taxa that are lucky or unlucky. The higher the speciation and extinction rates, the more likely it is that taxon richness will vary. For hexapods, the maximum likelihood estimate of speciation rate was $0.930 \text{ million years}^{-1}$, equivalent to that of angiosperms and birds estimated from the same methods, but much higher than that of primates (Table 3). The value is over 35 times the net rate of cladogenesis of hexapods (see above), and this difference arises from a similarly high estimated extinction rate. However, rather than representing high speciation and extinction rates, the differences across taxa more likely represent fundamental differences in the underlying rates of speciation and extinction in different subtaxa, and therefore Bokma's estimates are potentially dubious (e.g. Wilson, 1983; Labandeira & Sepkoski, 1993; Yang, 2001).

Eble (1999) used the fossil record of families to investigate trends in origination in three marine and three terrestrial taxa, one of which was insects. Proportional family origination in insects, in common with all other five taxa, shows a secular decline over time (Fig. 6). Though no statistical comparisons were made across the six taxa, the values for insects appear to be broadly consistent with those for mammals and pteridophytes plus gymnosperms, but lower than those for angiosperms. Explanations for the decline in proportional origination may be due to logistic growth, sorting of higher taxa or a decline in evolvability, or even in the probability of young taxa being assigned family status by taxonomists. The number of orders as opposed to families originating declines with time, also in common with other taxa.

Finally, speciation rates estimated from species-level phylogenies in two fly, one cricket and one beetle taxon range from 0.16 to $0.46 \text{ million years}^{-1}$ (Barraclough & Vogler, 2002; Coyne & Orr, 2004). These values are comparable to the net rates of cladogenesis estimated above.

(d) Extinction rates

The family-level record of hexapods suggests that extinction rates have been low relative to some other groups such as tetrapods (Labandeira & Sepkoski, 1993). The comparison is particularly striking in the Lyellian survival plots (Fig. 7). Lyellian survival plots show the proportion of taxa at each stage in the past that are still extant today, and are expected

Table 2. The described species richness of insect higher taxa (mainly orders) according to three different sources. In Parker (1982), numbers are the sum of family estimates where given

Order (common names)	Parker (1982)	Resh & Cardé (2003)	Grimaldi & Engel (2005)
Collembola (springtails)	Not given	9000	9000
Protura (proturans)	Not given	600	600
Diplura (diplurans)	Not given	1000	1000
Archaeognatha (bristletails)	280	500	500
Zygentoma (silverfish, firebrats)	334	400	400
Ephemera (mayflies)	2148	3000	3100
Odonata (dragonflies, damselflies)	Not given	5500	5500
Plecoptera (stoneflies)	1964	2000	2000
Embiidina (web-spinners)	200	300	500
Orthoptera (grasshoppers, crickets)	18644	20000	20000
Phasmida (stick-insects, leaf-insects)	2500	3000	3000
Zoraptera (angel insects)	20	32	32
Dermaptera (earwigs)	1506	2000	2000
Grylloblattaria (ice-crawlers)	13	25 +	26
Mantophasmatodea (heel walkers)	Not described then	2	15
Isoptera (termites)	1989	2600	2900
Mantodea (mantids)	1800	1800	1800
Blattaria (cockroaches)	3684	3500 to 4000	4000
Hemiptera (true bugs)	79977	94000	90000
Thysanoptera (thrips)	5000	5000	5000
Psocodea (book lice, lice)	5680	Phthirapteran (lice) : 4900, Psocoptera not given	4400
Neuropteroidea (lacewings, alderflies)	4610	6481	4900
Coleoptera (beetles)	336893	350000	350000
Hymenoptera (wasps, bees, ants)	130000	148002	125000
Trichoptera (caddisflies)	6411	11000	11000
Lepidoptera (butterflies, moths)	141764	160000	150000
Siphonaptera (fleas)	1740	2575	2500
Mecoptera (scorpionflies)	476	550	600
Strepsiptera (strepsipterans)	363	550	550
Diptera (true flies)	100000-150000	124000	120000

to be steeper for taxa that endure higher extinction rates. The curve for insects is much less steep, near the present, than for tetrapods (Fig. 7). A number of family-level extinctions occurred during the late Carboniferous and Permian and Early Cretaceous but tertiary extinctions have been minimal (Jarzembowski & Ross, 1996). The Quaternary fossil record supports these findings: a very high number of Quaternary insect species found in Britain are currently extant, though their ranges may have changed

Table 3. Estimates of speciation and extinction probabilities (million years⁻¹) for four higher taxa based on differences in species richness and ages of their component taxa. [After Bokma (2003) with permission from the Society for the Study of Evolution]

Taxon	Speciation rate	Extinction rate
Angiosperms	1.000	0.595
Birds	1.000	0.995
Hexapods	0.930	0.904
Primates	0.205	0.163

considerably (Coope, 1994). Similar findings come from the Canadian fauna (Matthews, 1980).

Stanley (1979) attempted to estimate species lifetimes of insects using the fossil record, but unsurprisingly, given its

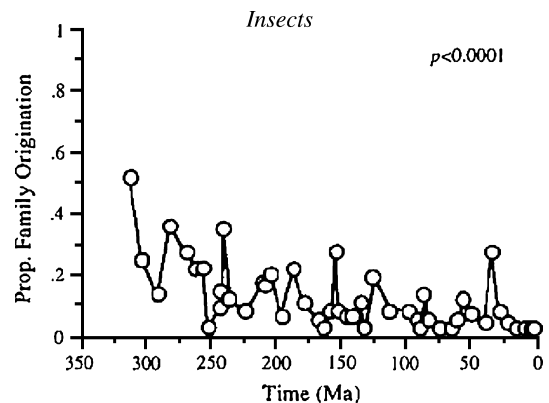

Fig. 6. The secular decline in insect family originations seen in the fossil record. Reprinted from Eble (1999) with kind permission from Elsevier.

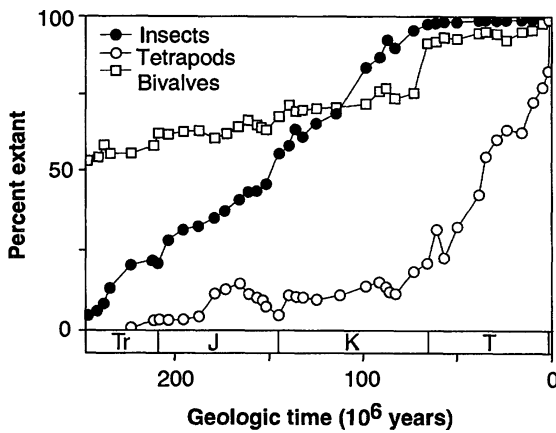

Fig. 7. Lyellian survival curves for insect families as well as bivalves and tetrapods. Insects have a much shallower curve near the present than tetrapods, implying a lower extinction rate. Reprinted from Labandeira & Sepkoski (1993), with kind permission from the American Association for the Advancement of Science. Copyright 1993 AAAS.

patchy nature at the species level, was unable to present firm conclusions. He estimated relatively low species lifetimes of 1–2 million years based on the scant evidence for recent species existing as fossils prior to the Pleistocene (Fig. 8). The implied extinction rates are relatively high, and contradict the conclusions from Quaternary evidence above (see also Wilson, 1983). In fact several putatively extant species have now been recorded from the Eocene, Oligocene and Miocene, at least some of which are undisputed. Ross, Jarzembowski & Brooks (2000) suggest therefore that most extant species appeared during the Miocene and Pliocene, giving insects potentially greater species lifetimes, and implied lower extinction rates than Stanley estimated.

By contrast, Bokma (2003) estimated a relatively high rate of extinction from the age and species-richness of the hexapod orders ($0.904 \text{ million years}^{-1}$), which was equivalent to that of birds but much higher than that of angiosperms and primates (Table 3). The dubious nature of these figures was explained in Section III.1c. Extinction rates in tiger beetles have been estimated at between 0.17 and $0.43 \text{ million years}^{-1}$, though two-parameter models performed only marginally better than a pure birth process and in one instance were actually inferior (Barraclough & Vogler, 2002).

Our knowledge of current (historic) extinction rates in insects, and their magnitude relative to other taxa, is equivocal. Studies can be found that both support the idea of low historic extinction rates in insects (Mawdsley & Stork, 1995; Hambler & Speight, 1996), or which suggest they are at least equivalent to or higher than other better recorded taxa (Thomas & Morris, 1995; J. A. Thomas *et al.*, 2004). Extremely few insect extinctions have been recorded, and most of them have been from charismatic taxa (Dunn, 2005). The levels of current range loss, extinctions, and red data book status of butterflies in Britain are actually higher than those seen in birds or flowering plants (Thomas &

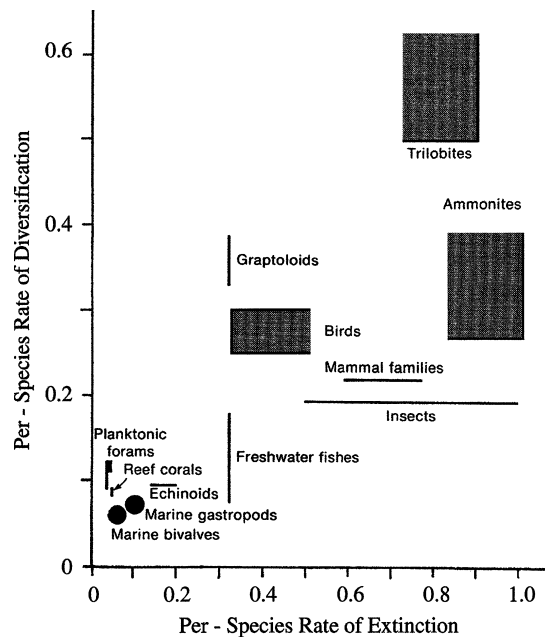

Fig. 8. Stanley's comparison of speciation and extinction rates across taxa. The y -axis is the net rate of cladogenesis, in insects estimated from extant species richness and taxon age. The x -axis is the extinction rate, measured as the reciprocal of species lifetimes, which in insects were estimated to be 1–2 million years. Extinction rates are positively correlated with the net rate of cladogenesis, which therefore means that speciation rates must be positively correlated with extinction rates. Reprinted from Sepkoski (1998), with kind permission of the Royal Society of London, after Stanley (1979). See text for discussion of the accuracy of the insect estimates.

Morris, 1995; J. A. Thomas *et al.*, 2004). However, some relatively well-known insect taxa have very low recorded extinction rates, for example tiger beetles, Odonata and macrolepidoptera in the USA (Dunn, 2005). Among the better recorded British insects, extinction rates are 0.7% per century, lower than the rates for flowering plants (0.9%), fish (3.0%), birds (1.0%) or mammals (2.0%). Particular problems concern how representative the best recorded taxa (e.g. butterflies and dragonflies) are, and to what extent range loss or rarity status at a national level reflects genuine global species extinction risk. These problems are unlikely to have simple or quick solutions.

An alternative approach to historic extinctions is to use some kind of predictive approach. Fagan *et al.* (2001) estimated risk of extinction from a large database of population time series, including 415 Lepidoptera species. The Lepidoptera were characterized by a very high proportion (97%) of species that probably rely on dispersal or other mechanisms for persistence because local extinction is a real possibility in a 100-year time horizon. However, they had a lower predisposition to extinction than marine fishes from environmental variability. C. D. Thomas *et al.* (2004) conducted a similar predictive study on species extinction from climate change, including 69 butterfly species. These indicated roughly equivalent

extinction risks from climate change compared to other taxa, though there are some critical unknown variables such as how well different taxa can disperse to follow their climate envelopes.

(e) Evidence for limits to species richness

Labandeira & Sepkoski (1993) used a semi-log diversity plot (see Fig. 4) to look for evidence for a slow-down in the rate of increase in families. The plot, starting after the end-Permian mass extinction, indicates exponential growth up to the mid-Cretaceous, but with some deviation from exponential growth after that, indicative of logistic growth. However, given that about half the fossil families only appear after the end of the Mesozoic (Fig. 5), it is clear that any logistic slow down is relatively mild (see also Benton, 1995, 2001). Unlike some marine taxa, terrestrial taxa in general, including insects, show no relationship between total diversity and origination rate (Eble, 1999) (Fig. 9).

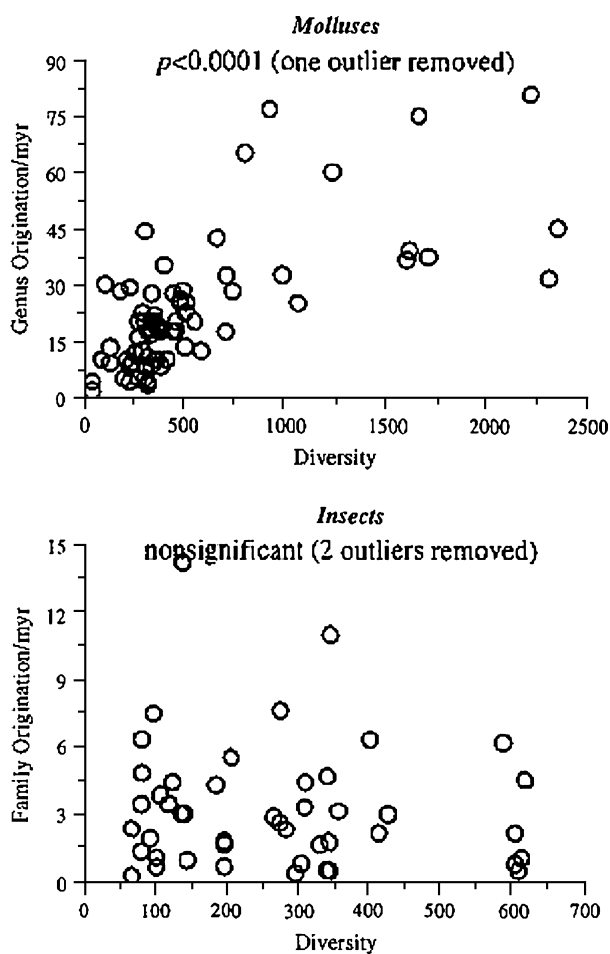

Fig. 9. Eble's (1999) test for logistic growth by searching for an asymptotic relationship between origination rates and standing diversity. In insects there is no association, in contrast to molluscs which show a significantly non-linear relationship. myr, million years. Reprinted from Eble (1999) with kind permission from Elsevier.

The ordinal-level phylogeny of insects contains little evidence of a slow-down in net rates of diversification, though origination of new orders occurs mainly in the Palaeozoic. It shows that progressively more recently originating orders have radiated at progressively higher rates (Mayhew, 2002), rather than the lower rates expected from logistic models, or the constant rates assumed by exponential models (Fig. 10). The ultimate processes underlying this trend are discussed below. Rather interestingly, although many nodes imply an increase in the net rate of cladogenesis, so many others imply a decrease (Mayhew, 2003). Primary amongst these are species-poor taxa that are nested amongst species-rich taxa: they include the Grylloblattaria, Zoraptera, Strepsiptera, Mecoptera, Siphonaptera, Embiidina, Protura, Trichoptera, Neuropteroidea, Zygentoma and Archaeognatha (Mayhew, 2003) (Fig. 10). All of these however probably originated well before any logistic effects implied by the fossil record (Mayhew, 2002).

At finer taxonomic levels there is a long history of asking whether species richness or phylogenetic data are consistent with simple null models of cladogenesis (see Mooers & Heard, 1997). Yule (1924) was the first to do this, applying the pure birth model to data and ideas provided by Willis (1922). He showed that the species richness of different chrysomelid and cerambycid beetle genera were generally consistent with this model, implying no slow-down in rate. More recently researchers have used phylogenetic data in place of the species richness of equivalent taxa, and these also show no evidence for a slow-down in the rate of cladogenesis (Ribera, Barraclough & Vogler, 2001; Barraclough & Vogler, 2002), and one of these actually shows a slight increase (Fig. 11). Hey (1992) showed that several species-level phylogenies, including three insect clades, better fit the pure birth model than a model in which speciation is always accompanied by extinction.

De Queiroz (1999, 2002) posed a hypothesis of radiation contingent on available niche space and tested it against the idea that image-forming eyes are a key innovation. Consistent with this, he found that the first three taxa to evolve image-forming eyes, arthropods, vertebrates and cephalopods, had diversified much more rapidly than taxa that evolved them subsequently (Fig. 12). If this hypothesis is true, it suggests that part of the reason for the initial and sustained radiation of insects may have been their early colonization of the land, and hence by implication the age of insects has promoted their diversity through raising the limit to species richness.

(2) Ultimate variables – morphology

(a) Insect body ground plan

Phylogenetic studies indicate that being an insect *per se* is no guarantee of species richness. Relative to other, non-insect hexapods (the Entognatha), the primitive wingless insects (Apterygota) have not radiated significantly faster (Mayhew, 2002, 2003). Only taxa that acquired other characteristics really began to radiate rapidly (Fig. 10), and therefore whilst the insect body ground plan may have been necessary for species richness, it may not have been sufficient. A proviso is that the above analyses assumed a monophyletic Hexapoda.

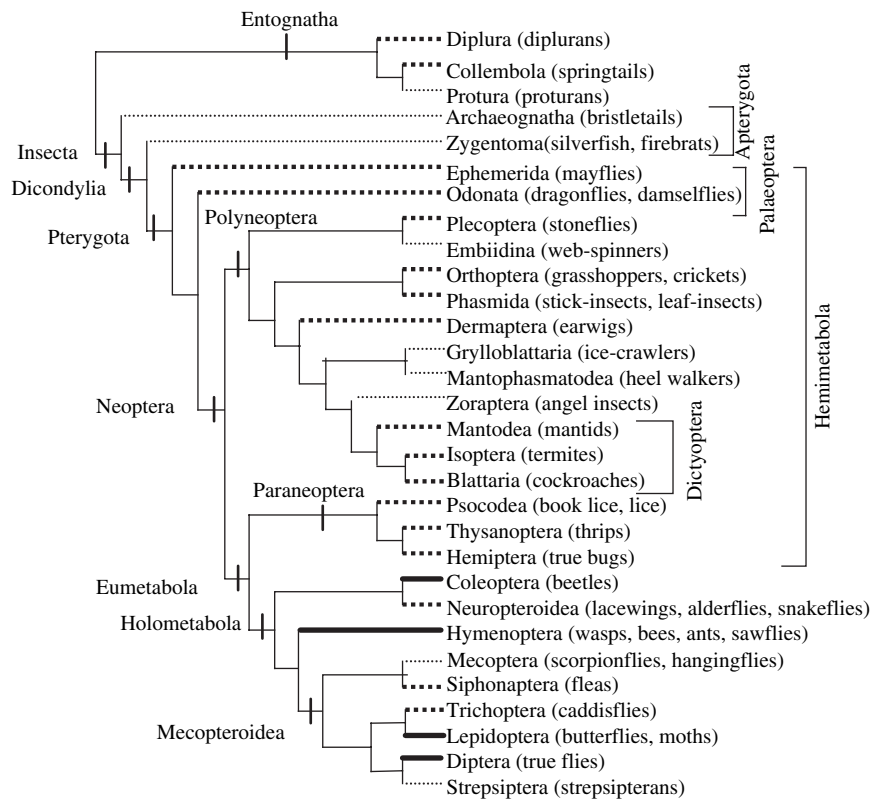

Fig. 10. A possible phylogeny of the extant hexapod orders, with higher taxa as used in the text. Time is not shown to scale. For other possible phylogenetic relationships, see text. Thick solid branches: $>10^5$ described extant species, thick dashed branches $10^5 - 10^3$ species, thin dotted branches $<10^3$ species (see Table 2).

Several recent phylogenetic studies have suggested that the Entognatha might have originated independently from Crustacea (Nardi *et al.*, 2003; Giribet *et al.*, 2004; Pisani, 2004). This requires confirmation from further studies, but if it were upheld then a next step would be to identify the sister taxon of the Insecta amongst the Crustacea (see Glenner *et al.*, 2006 and references therein), and its species richness. One could then re-test the effect of the insect body ground plan as above.

Zeh, Zeh & Smith (1989) identify a number of modifications to the egg and egg-laying apparatus in primitive insects relative to the Entognatha, and cite that the marked difference in diversification between the insects and Entognatha is consistent with a role for egg and egg-laying structures. Whilst this is true, the relatively low diversity of Apteriygota suggests that these modifications were not sufficient, though they may have been necessary.

(b) Flight/wings/dispersal

De Queiroz (1998) asked if the species richness of the three extant winged taxa (birds, the Pterygota and bats) and their extant sister groups implies overall whether flight generally increases net diversification rates. His discussion may be interpreted as a cautious “yes”, and is an interesting example of the problem of interpreting key innovations with low evolutionary replication.

Mayhew (2002) showed that the species richness of pterygotes is much greater than that expected if they and their sister group diversified at the same rates (Fig. 10). However, significant differences between sister taxon richness also occur within the Pterygota (Fig. 10). This means that the significant difference identified between pterygotes and their sister group could be a result of the so-called “trickling down” effect (Fig. 13), which occurs when a later radiation amongst derived taxa raises the species richness of higher taxa to which it belongs (see Moore, Chan & Donoghue, 2004). Mayhew (2002) used comparisons between the most primitive ingroup member and the outgroup to control for such effects. After this control, wings are not significant, though if the Palaeoptera are monophyletic (e.g. Hennig, 1981; Hovmöller, Pape & Kallersjö, 2002), non-significance is fairly marginal.

In a related descriptive analysis, Mayhew (2003) used parsimony to estimate the change in net rate of diversification across nodes. On average across four possible phylogenies, the Pterygota node represented the eleventh largest shift across the ordinal tree, and on average represented a greater shift than for the Holometabola (origin of complete metamorphosis), Neoptera (origin of folding wings) and Insecta. It was however, because of its antiquity, the shift estimated to have had the second greatest effect on current species richness. A further consideration is that the effect of wings might not be manifested until

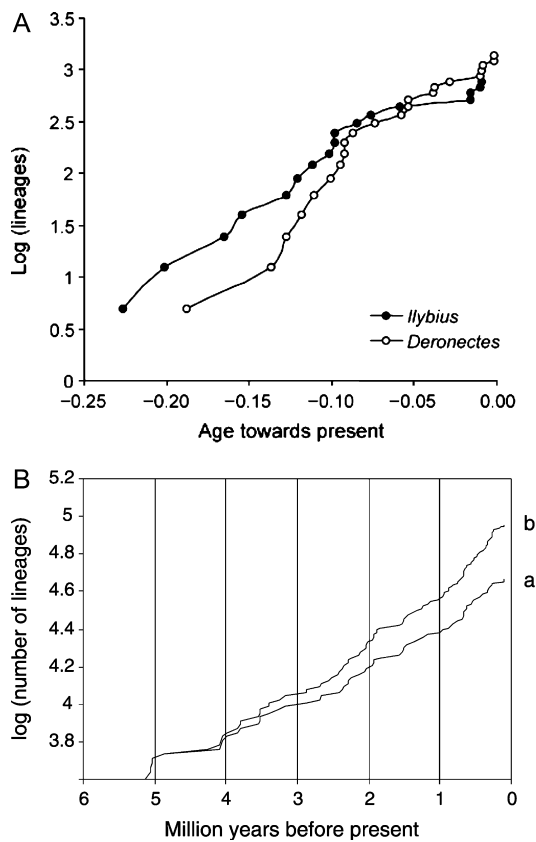

Fig. 11. Semi-log plots of clade species richness from some species level phylogenies of beetles. Top panel: two genera of water beetles, shown on a relative temporal scale. Both show a suggestion of a slow-down in rate, though neither is statistically significant. Reprinted from Ribera *et al.* (2001) with kind permission of Blackwell publishing. Bottom panel: tiger beetles of the genus *Cicindela*. a shows species in the actual phylogeny; and b is a plot with species not sampled added in. In this case there is a weak but significant suggestion of an increase in diversification towards the present, consistent with the idea that Pleistocene glaciations have facilitated speciation in this group. Reprinted from Barraclough & Vogler (2002), with kind permission from Oxford University Press.

combined with some other key innovation (such as wing folding, or complete metamorphosis).

One of the possible reasons for enhanced rates of diversification by wings (dispersal ability) has been addressed by comparing the net rates of diversification in the lentic (widespread) waterbeetle *Ilybius* with that in the lotic (local) waterbeetle *Deronectes*. The difference is in the expected direction (higher species turnover in *Deronectes*) but not significant (Ribera *et al.*, 2001) (Fig. 11). Several studies have asked if dispersal ability is associated with a measure of present-day extinction risk (Table 4). In Finnish butterflies, dispersal ability was negatively correlated with red data book status (Kotiaho *et al.*, 2005) (Fig. 14). Similarly, in European hoverflies, an increase in flight period (possibly indicating dispersal ability) is correlated with a decreased red data book status (Sullivan

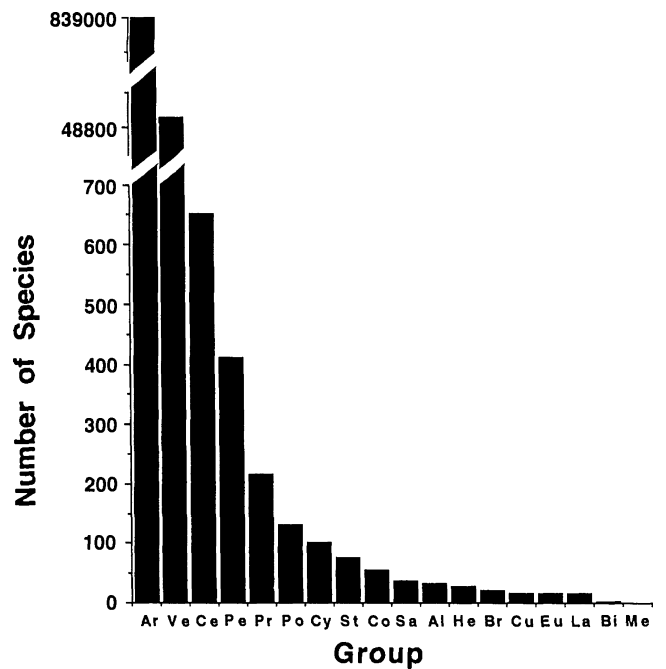

Fig. 12. The species richness of taxa with image-forming eyes. Most taxa with image-forming eyes have relatively low diversity, but the first three to evolve them (on the left) have all attained very high diversity. This is consistent with a hypothesis of radiation contingent on available niche space. The three diverse taxa on the left are arthropods (Ar), vertebrates (Ve) and cephalopods (Ce). Reprinted from de Quieroz (1999) with kind permission from the Society for the Study of Evolution.

et al., 2000). This is also the case in Finnish noctuid moths (Mattila *et al.*, 2006). In ground beetles from the low countries, species with both long and short wing morphs are less likely to have declined than those with only one wing morph (Kotze & O'Hara, 2003). Nieminen (1996) used wing span as a measure of dispersal ability in Finnish Lepidoptera, but found no relationship to extinction risk. Shahabuddin & Ponte (2005) measured wing loading in frugivorous butterflies and found it to be positively related to extinction risk, but not when controlling for body size. British and Dutch hoverflies that are migratory have declined less than those that are residents (Biesmeijer *et al.*, 2006). Finally, Thomas (2000) found a marginally non-significant negative relationship between regional extinctions and dispersal in British butterflies, but that species with intermediate dispersal ability had the highest extinction rates at a local scale, probably because very sedentary species required smaller areas of habitat. Thus dispersal ability is at least sometimes related to extinction risk, but not always in simple ways.

(c) *Folding wings*

The acquisition of wings, whilst resulting in an increase in the realized rate of radiation, did not do so significantly over the long term in the most primitive surviving orders

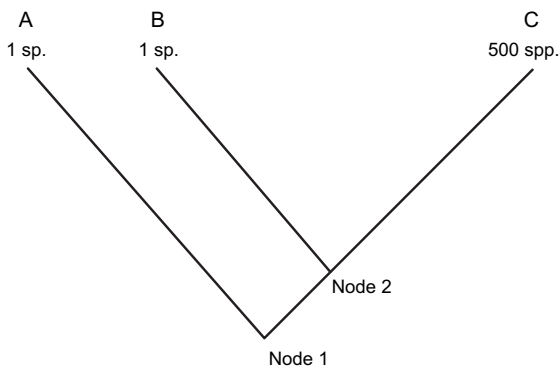

Fig. 13. The “trickling down” problem. Three taxa are shown, A, B, and C, where B & C are sisters, and are themselves the sister to A. We wish to know whether rates of diversification have shifted at Node 1 or Node 2. Clearly here, rates have shifted at Node 2. However, a single test for equal rates at Node 1 will produce a low probability because an increase in the rate of diversification within C has raised the species richness of (B+C), such that it is collectively much more diverse than A: hence the significance at Node 2 has “trickled down” the tree to Node 1. Mayhew (2002) avoided this problem by testing the difference between A and B when B+C are significantly different (i.e. discounting C). T.J. Davies *et al.* (2004) instead replaced the species richness of C with that of B and then tested A against (B+C). Both methods would then produce a non-significant result at Node 1, effectively eliminating trickling down.

(Odonata and Ephemera) (Mayhew, 2002). These extant paleopterous insects are arguably hindered in their ability to exploit ecological niches as adults by wings that cannot be folded flat over the abdomen. With the advent of folding wings however (the Neoptera, Fig. 10), rates of radiation did increase significantly as long as the Polyneoptera are assumed to be monophyletic (e.g. Boudreaux, 1979; Mayhew, 2002) (Fig. 10). If not (e.g. Wheeler *et al.*, 2001), the Eumetabola or some slightly more inclusive group represent significant radiations instead (Mayhew, 2002).

(d) Complete metamorphosis

Yang (2001) used the fossil record of insect families to ask if net rates of cladogenesis and extinction have varied between the Hemimetabola (taxa with incomplete metamorphosis, without a pupa, Fig. 10) and the Holometabola (taxa with complete metamorphosis with a pupa, Fig. 10). In all but four geological stages (6–20 million year intervals), holometabolous insects produced a greater net rate of diversification than their hemimetabolous sister group, the Paraneoptera (called Eumetabola by Yang, 2001) (Fig. 15). Furthermore, the Hemimetabola as a whole and Holometabola showed similar Lyellian survival curves, indicating similar rates of extinction (Fig. 16). Thus, the difference in the net rate of diversification must be due to higher origination rates or increased limits to species richness in the Holometabola. This result is attractive as it conforms to the functional notion that complete metamorphosis opened

up a broader array of niches for both juveniles and adults. By contrast, Ross *et al.* (2000) claimed that holometabolous insects may have shown lower extinction rates than other insect taxa during the end Cretaceous event (see Figs 10–13 in Jarzembowski & Ross, 1996).

The comparison between the current species richnesses of Paraneoptera and Holometabola does not provide strong support for differences in rates of cladogenesis. Although the Holometabola are very much larger in species richness terms (Table 2, Fig. 10), because of the exponential growth of clades this does not equate to a very large difference in the rates of cladogenesis (0.0472 *versus* 0.0399 million years⁻¹), and is consistent with stochasticity in the same underlying rate (Mayhew, 2002). Mayhew (2003) estimated that there were at least 17 shifts in realized rate of greater magnitude within the hexapods, though only seven with a greater effect on species richness.

(e) Mouthparts

A substantial percentage (65–88%) of extant insect mouthpart classes (total 34) were in existence by the mid-Jurassic, prior to the great radiation of angiosperms (Labandeira & Sepkoski, 1993) (Fig. 5). This disparity of trophic machinery may thus have contributed to the great increase in the number of insect families during the Cretaceous and Tertiary, but it was not the result of it. Labandeira (1997) details five periods of mouthpart innovation, two of which (Pennsylvanian and early Permian) are associated with the initial radiation of winged insects. The fourth and fifth phases (late Triassic to early Jurassic and late Jurassic to Early Cretaceous) took place during the sustained diversification of families during the entire Mesozoic and Tertiary (Fig. 5).

(f) Exoskeleton/cuticle, segmentation, appendages and eggs

The exoskeleton and cuticle are features of arthropods, but also other phyla. Nee, Barraclough & Harvey (1996) used extant species richness comparisons to show that the arthropods are a significant radiation relative to other phyla that originated in the Cambrian explosion: whether this is a result of insects especially or is a trait common to all arthropods is presently unclear. However, in the Cambrian period, well prior to the colonization of the land, the arthropods were by far the most abundant, speciose and disparate group (e.g. Wills, Briggs & Fortey, 1994). The importance of the cuticle relates both to its adaptability (e.g. mouthparts see above) and also to its role in allowing the colonization of the land, as an impermeable barrier to facilitate internal homeostasis. The comparison between the marine and continental fossil record has been made at least qualitatively. Benton (1995, 2001) claimed that (exponential) net rates of diversification were higher in continental than marine families. Zeh *et al.* (1989) drew attention to innovations of the insect egg and oviposition behaviour that may have played a role in their successful colonization of new terrestrial habitats, and showed that these unique innovations are generally associated with an increase in species richness in extant taxa that possess them (Table 5).

Table 4. Species-level comparative studies of the factors affecting current or historic extinction risk in insects

Reference	Taxa included	Measure of extinction risk	Explanatory variables (relationship to extinction risk: 0, no significant effect; +, positively related to extinction risk; -, negatively related to extinction risk)	Statistical methods used
Benedick <i>et al.</i> (2006)	84 butterfly species in Borneo	Difference in density between large and small forest fragments	Host plant specialization (+), body size (+, marginally ns), geographic range (0)	Standard statistics, subfamily included as categorical explanatory variable
Biesmeijer <i>et al.</i> (2006)	British and Dutch bees (29–56 spp) and hoverflies (50–88 spp).	Changes in number of 10 km ² grid cells occupied	In bees: habitat range (-), flower specificity (-), tongue length (-), voltinism (-). In hoverflies: habitat range (-), adult food (-), larval food (-), voltinism (-), migratory (-).	Standard statistics, no accounting for phylogeny
Davies <i>et al.</i> (2000)	69 beetle species in fragmented forest in SE Australia	Log ratio of abundance of beetles in fragments to beetles in control plots in continuous forest	Abundance(-), geographic isolation (0), body size (0), trophic level (+), phylogeny (0)	Multiple regression, effect of phylogeny assessed by the significance of “family” included as a categorical variable
K. F. Davies <i>et al.</i> (2004)	71 beetle species in fragmented forest in SE Australia	Log ratio of abundance of beetles in fragments to beetles in control plots in continuous forest	Abundance(0), body size (0), trophic group(0), habitat specialization (+) plus two-way interactions (extinction risk did not decline with abundance in generalists, only in specialists)	Multiple regression, no accounting for phylogeny (but see above)
Didham <i>et al.</i> (1998)	32 beetle species from Amazonia	Whether the probability of local extinction was positively, negatively or not related to forest fragment area	Body size (0), density in continuous forest (+), variability of populations (+), trophic group (0)	Standard statistical tests, no accounting for phylogeny
Koh <i>et al.</i> (2004)	381 butterflies in Singapore	Proportion of species lost	Adult habitat specialization (+), host-plant specialization (+), geographic range (-, marginally ns), sexual dichromatism (-), congenor density (+), larval behaviour (0), egg-laying behaviour (0), adult conspicuousness (0), migratory pattern (0), body size (0)	Standard statistics, family included as covariate
Korkeamäki & Suhonen (2002)	20 Odonata species in Finland	Persistence of local populations identified from atlas	Regional range size (-), lotic (-) or lentic (+)	Standard statistical tests, no accounting for phylogeny

Table 4 (cont.)

Reference	Taxa included	Measure of extinction risk	Explanatory variables (relationship to extinction risk: 0, no significant effect; +, positively related to extinction risk; -, negatively related to extinction risk)	Statistical methods used
Kotiaho <i>et al.</i> (2005)	95 Finnish butterfly species	Finnish Red list classification	Population density (+), food plant specialization (+), food plant geographic range (-), dispersal ability (-), habitat specialization (+), flight period (-), body size (0)	Standard statistical tests (no accounting for phylogeny)
Kotze & O'Hara (2003)	Ground beetles (Carabidae) in Belgium, Denmark and The Netherlands (379, 314, 380 spp)	Changes in range size and number of records	Body size (+), habitat specialization (+), degree of wing size dimorphism (-), closed habitats (- for large, + for small spp.) versus open habitats	Ordinal regression, with tribe used as a factor to account for phylogenetic effects
Krauss <i>et al.</i> (2003)	61 butterfly species in Germany	Local population extinction in 31 calcareous grasslands over 4 years	Habitat specialization (+)	Standard statistics, no attempt to control for phylogeny
Kruess & Tschamntke (1994)	8 herbivores (6 beetles, 1 wasp, 1 fly) and 13 parasitoid wasp species on red clover patches in Germany	Proportion of patches from which species was absent	Population variability across patches (+), mean species abundance (-)	Standard statistical tests (no accounting for phylogeny)
Kruess & Tschamntke (2000)	4 herbivores (3 beetles, 1 moth), 10 parasitoids (wasps) on bush vetch in German meadows	Absence rate (proportion of meadows from which species was absent)	Population variability across meadows (+), mean species abundance (0)	Standard statistical tests (no accounting for phylogeny)
Mattila <i>et al.</i> (2006)	306 Finnish noctuid moth species	Red data book status, geographic range, and distribution change	Body size (0), larval resource distribution (-), flight period (-), overwintering stage (+)	Independent contrasts
Nieminen (1996)	186 Lepidoptera species on Finnish islands	Parameter x , estimated from an incidence function metapopulation model applied to occurrence data (high values of x indicate low risk of extinction)	Family (marginally significant), macro- <i>versus</i> microlepidoptera (0), monophagy (+) <i>versus</i> polyphagy (-), hosts annuals (+) <i>versus</i> perennials (-), hosts woody <i>versus</i> non-woody (0), woody hosts coniferous (-) <i>versus</i> deciduous (+), exophytic <i>versus</i> endophytic (0), overwintering stage (0), wing span (0),	Standard statistical techniques, family included as a factor to control for phylogeny

Shahabuddin & Ponte (2005)	20 species of frugivorous butterflies in Venezuelan dry forest	Changes in population densities in forest fragments and control sites	Body size (+), wing loading (+), phylogeny (0), control population density (0)	Mantel tests, phylogeny controlled for using phylogenetic distance (from taxonomy) as an explanatory variable
Sullivan <i>et al.</i> (2000)	244 British hoverfly species (Syrphidae)	British and German red data book status	Wing length (+), flight period (-), habitats occupied (0), single or multi-brooded (0)	Independent contrasts
Thomas (2000)	56 British butterflies	Regional extinction rates, local population extinction rates from replicated atlas data	Mobility (-, marginally ns at regional scale, local population extinction highest amongst intermediate mobility species)	Standard statistical tests (no accounting for phylogeny)

ns, not significant.

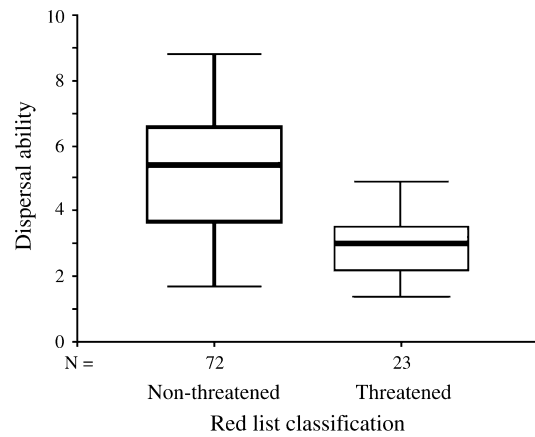

Fig. 14. The current risk of extinction in Finnish butterflies (measured as status in the Finnish Red List) against their dispersal ability, measured on an index from 1–10. Non-threatened species are significantly better dispersers than threatened species. Reprinted from Kotiaho *et al.* (2005) with permission. Copyright 2005 National Academy of Sciences, U.S.A.

(g) *Sensory and neurosophistication*

One aspect of neurosophistication, image-forming eyes, has been related to species richness (de Queiroz, 1999, 2002). This study found that there was no consistent correlation between species richness and image-forming eyes, but three of the taxa that had evolved them (one being arthropods) had given rise to very large radiations and these were also the first to evolve them (Fig. 12). The data are therefore consistent with the idea that image-forming eyes permit large radiations but only amongst the first groups to evolve them.

(h) *Small body size*

Body size is a continuous character and so its effect on species richness can be analysed across phylogenies at every

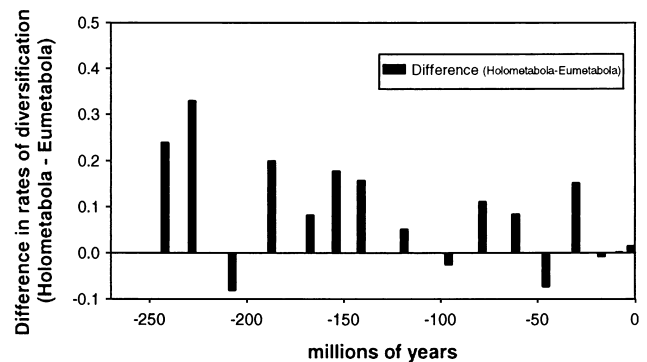

Fig. 15. Normalized rates of diversification in the Holometabola (relative to the Paraneoptera (called Eumetabola in the figure) over its evolutionary history. Rates have generally represented an increase relative to those of the Holometabola’s sister taxon. Reprinted from Yang (2001) with kind permission from Blackwell Publishing.

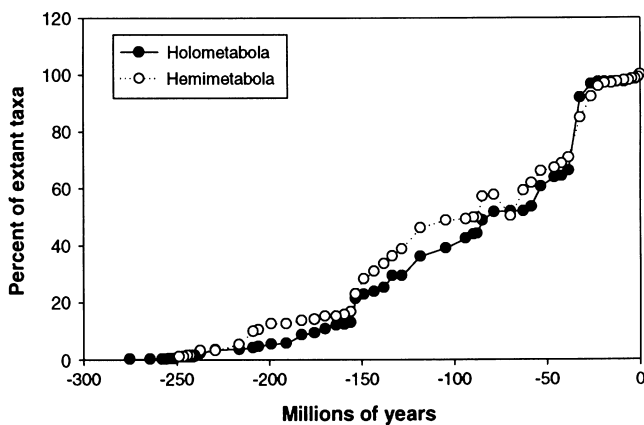

Fig. 16. Lyellian survival curves (see Fig. 7) for the Holometabola and Hemimetabola (see Fig. 10 for definitions). The curves are not significantly different, indicating that the two taxa, and hence their different forms of metamorphosis, have had no effect on extinction rates. Reprinted from Yang (2001), with kind permission of Blackwell Publishing.

node (e.g. using the methods of Agapow & Isaac, 2002; Isaac *et al.*, 2003; see Table 5). Across 19 species-level phylogenies (Orme, Isaac & Purvis, 2002) there was evidence for a significant effect in just one (*Bilheca* flies, a negative and highly significant effect). No significant effect of body size was found in a separate study on hoverflies (Katzourakis *et al.*, 2001). By contrast, sister-taxon comparisons using higher taxa of Anisoptera (Odonata) revealed a significant *increase* in species richness with body size (Misof, 2002). These results may seem surprising given the well-known *decrease* in species richness with body size in extant communities (e.g. May, 1978) but there are mitigating circumstances. The species-level phylogenies in the Orme *et al.* (2002) study do not show significant skew in the frequency distribution of body sizes. This appears only to be a property of larger clades. The tests are therefore not really fair tests of the hypothesis. Gardezi & da Silva (1999) showed in mammals that despite no significant relationship between the net rate of diversification and body size, the largest radiations tended to occur amongst small-bodied clades. It is possible that similar patterns will be found in the insects.

Body size has been related to present day extinction risk in several studies (Table 4). In several studies body size is positively related to extinction risk (Sullivan *et al.*, 2000; Kotze & O'Hara, 2003; Shahabuddin & Ponte, 2005; Benedick *et al.*, 2006), and in several others there is no association (Nieminen, 1996; Didham *et al.*, 1998; Davies, Margules & Lawrence, 2000; Davies, Margules & Lawrence, 2004; Koh, Sodhi & Brook, 2004; Kotiaho *et al.*, 2005; Mattila *et al.*, 2006).

(3) Ultimate variables – ecology and behaviour

(a) Interspecific interactions and specialization

The primary types of interaction postulated to have increased the species richness of insects are those with

plants. Labandeira & Sepkoski (1993) showed that the rate of diversification of insect families was not immediately increased by the radiation of angiosperms (Fig. 4). Insect family richness certainly continued to rise after the radiation of the angiosperms (Figs 4, 5). Ross *et al.* (2000) and Jarzembowski & Ross (1996) show that there was considerable faunal turnover during the early Cretaceous with both high origination rates and high extinction rates, and they attribute this to the rise of the angiosperms.

There have been many phylogenetically based studies of the relationship between plants and species richness. In a landmark sister-taxon study, Mitter, Farrell & Wiegmann (1988) showed that phytophagy has tended to increase the species richness of those groups that have acquired it. A subsequent study within the Phytophaga (Coleoptera) confirmed that this has also been the case for associations with angiosperms, often spectacularly so (Farrell, 1998) (Table 5).

One of the mechanisms by which plants might have increased the species richness of insects is co-evolution. Phylogenies can help the detection of co-evolutionary processes that affect diversity. A few cases exist of co-speciation between plants and insects: the most repeated cases come from fig/fig wasps (see Jackson, 2004) (e.g. Fig. 17). More generally however, insects and plants show a looser phylogenetic association, such that closely related insects are hosted by closely related plants, but with little co-speciation (e.g. Janz & Nylin, 1998). This suggests that speciation in plants does drive speciation in insects but not through parallel cladogenesis. Instead, plant diversity affords the opportunity for future insect diversity through host switching. Specialization is possibly an important influence therefore.

Phytophagy is, clearly though, not the end of the explanation for either insect or beetle species richness, as there are many very species-rich groups both in and outside this order that are not primarily phytophagous (Barraclough, Barclay & Vogler, 1998). Other interactions may have played a role in insect species richness. Micro-organisms, particularly symbiotic ones, appear to have co-speciated on numerous occasions with their insect hosts. In some cases, speciation in the insects may cause parallel cladogenesis in the symbionts, but in other cases, such as *Wolbachia*, the symbiosis itself may be reason for the insect diversification (e.g. Thompson, 1987). Insect parasites have also co-speciated with their hosts (lice) (see Johnson & Clayton, 2003). This seems likely to have been driven through the hosts rather than the insects. Wiegmann, Mitter & Farrell (1993) showed that carnivorous parasitism is, unlike plants, not a consistent key innovation, despite some very large radiations amongst members of this trophic guild (particularly in the Hymenoptera). It would be valuable to explore the macroevolutionary effect of other trophic niches such as fungivory and saprotrophy in a similar way.

Present-day extinction risk has been related both to the type of interactions and their specificity (Table 4). Of three studies of tropical forest beetle assemblages, one found that high trophic levels are more susceptible to extinction (Davies *et al.*, 2000), and two others found that the variable is not significant (Didham *et al.*, 1998; K. F. Davies *et al.*, 2004). Several other similar studies conducted at a community

Table 5. Tests of replicated key innovation hypotheses within or involving insects. Effect size for categorical characters (the richness comparison) is estimated for each sister-pair as the richness of the larger clade divided by the richness of the smaller clade, with the sign positive if it is in the direction expected under the hypothesis and negative otherwise

Reference	Null hypothesis	Data	Null hypothesis rejected?	Effect size	Likely impact on species richness
Arnquist <i>et al.</i> (2000)	Polyandrous clades have the same species richness as monandrous clades	25 paired contrasts between genera or families in five orders	Rejected: polyandrous clades richer in 18 cases	Mean richness comparison +5.16	Very large ($>10^5$ spp.): the majority of insects are polyandrous
Cardillo (1999)	Latitude is not associated with species richness	13 paired comparisons of swallowtail butterflies	Rejected: tropical clades more species rich	Mean richness comparison +2.10	Possibly typical of other groups, but in this case $>10^5$ spp. None
Connor & Taverner (1997)	Leaf-mining clades have the same species richness as those with external feeding niches	7 paired contrasts in Coleoptera and Hymenoptera	Not rejected: tendency for leaf mining clades to be less species rich	Mean richness comparison -6.53	
de Queiroz (1998)	Flight has promoted diversification	3 paired contrasts, 1 of which is in insects	Rejected: flight increases species richness	In insects, richness comparison is +1973	Very large: ($>10^5$ spp.) though see Mayhew (2002)
de Queiroz (1999, 2002)	Image-forming eyes have promoted diversification	12 paired contrasts, one of which is arthropods	Not rejected, BUT major radiations occurred significantly earlier than minor ones, consistent with a hypothesis of contingent radiation	Arthropod richness comparison is +11.8 or +8390 depending on sister taxon	Possibly very large, but these are general features of arthropods
Farrell (1998)	Beetle clades associated with angiosperms have the same species richness as clades associated with gymnosperms	5 paired contrasts within Coleoptera	Rejected: clades associated with angiosperms have higher richness	Mean richness comparison +452.23	Very large: ($>10^5$ spp.), associations with angiosperms very common
Katzourakis <i>et al.</i> (2001)	Body size, ovariole number, egg size, spermathecal width, testis and tongue length are unrelated to species richness in hoverflies	40-53 contrasts across 204 genera and subgenera	Rejected for testis length and tongue length; both positively related to species richness	All contrast slopes positive, 0.39 for testis length, 0.51 for tongue length	<i>Circa</i> 10^3 spp. in this group, but possibly many more
Misof (2002)	Sexual dimorphism, body size, and short life cycles are not associated with species richness in dragonflies	Paired contrasts within the Anisoptera (Odonata): 8 pairs for sexual dimorphism, 11 for body size, 13 for voltinism	Rejected for sexual dimorphism and size. More dimorphic and larger bodied clades are more species rich	Mean richness comparison for sexual dimorphism: +6.95; for body size: +6.11	<i>Circa</i> 10^3 species in this group, but possibly many more
Mitter <i>et al.</i> (1988)	Phytophagous clades have the same species richness as non-phytophagous clades	13 paired contrasts in 5 orders	Rejected: phytophagous clades more species rich	Mean richness comparison +160.90	Very large: ($>10^5$ spp.), about 50% of insect spp. phytophagous

Table 5 (cont.)

Reference	Null hypothesis	Data	Null hypothesis rejected?	Effect size	Likely impact on species richness
Orme <i>et al.</i> (2002)	Body size is not associated with species richness	Nested sister-taxon contrasts in 19 genera or species groups in 6 orders	Rejected in only 1 clade (<i>Bitheca</i>).	Mean contrast slope is -0.75	None on its own
Wiegmann <i>et al.</i> (1993)	Carnivorous parasitism is not associated with species richness	19 paired comparisons in 9 orders	Accepted: parasitic groups only more species rich in eight cases	Mean richness comparison $+24.46$	None on its own
Zeh <i>et al.</i> (1989)	Use of novel oviposition substrates is not associated with species richness	14 paired contrasts, 11 within Insecta	Rejected: group using novel substrates has higher species richness	Mean richness comparison in insects $+12.97$	Very large: ($>10^5$ spp.): changes account for some very rich groups

rather than species level suggest some support for low extinction rates in herbivores relative to higher trophic levels (see Tschardt *et al.*, 2002). Thus, the species richness of phytophagous insects might be high because of low extinction rates.

As well as trophic level, many studies of present-day extinction risk have included habitat or host-plant specialization as an explanatory variable. Of seven studies addressing habitat specialization (Table 4), six find a positive association between habitat specialization and extinction risk. The six studies include two on beetles (Kotze & O'Hara, 2003; K. F. Davies *et al.*, 2004) three on Lepidoptera (Krauss, Steffan-Dewenter & Tschardt *et al.*, 2003; Koh *et al.*, 2004; Kotiaho *et al.*, 2005), and one on both bees and hoverflies (Biesmeijer *et al.*, 2006). This provides support for a link between extinction risk and habitat specialization in the intuitive direction, but cannot explain the high species richness of specialized insects, particularly phytophages. It does however tend to direct us towards speciation processes rather than extinction processes as a possible explanation. The non-significant result comes from Red data book comparisons of hoverflies (Syrphidae) (Sullivan *et al.*, 2000).

In addition some studies have addressed the effect of geographic range size (of the subject species or its host), which is often taken as a surrogate of niche specialization. Of five studies, four find a negative relationship between extinction risk and geographic range size (Korkeamäki & Suhonen, 2002; Koh *et al.*, 2004; Kotiaho *et al.*, 2005; Mattila *et al.*, 2006), and one no significant association (Benedick *et al.*, 2006) (Table 4). Again, this relationship is intuitive, and supports the findings from habitat specialization. Finally, five studies have addressed the effect of host-plant specialization in Lepidoptera on present day extinction risk (Table 4). They all find positive associations (i.e. more specialized insects have higher extinction risks) (Nieminen, 1996; Koh *et al.*, 2004; Kotiaho *et al.*, 2005; Benedick *et al.*, 2006; Mattila *et al.*, 2006). Biesmeijer *et al.* (2006) found similar effects for range declines in bees and hoverflies, related to both adult food specificity as well as for the larvae of hoverflies.

(b) Sexual selection and sexual conflict

Sexual selection describes the variation in fitness due to mate acquisition and success in fertilization. Sexual selection has been hypothesized to increase speciation rates *via* enhancing reproductive isolation. Katzourakis *et al.* (2001) found a positive relationship between testis length and species richness in hoverflies which might be indicative of sexual selection through sperm competition. Misof (2002) also found a (marginally) significant positive association between the degree of sexual colour dimorphism and species richness in Anisoptera (Odonata) (Table 5).

A related issue is that of sexual conflict. Arnqvist *et al.* (2000) used polyandry as a phenotypic marker for sexual conflict. In polyandrous clades each female mates with more than one male, hence there may be selection for males to disregard or even harm the fitness of females if it will increase their own reproductive success in the face of

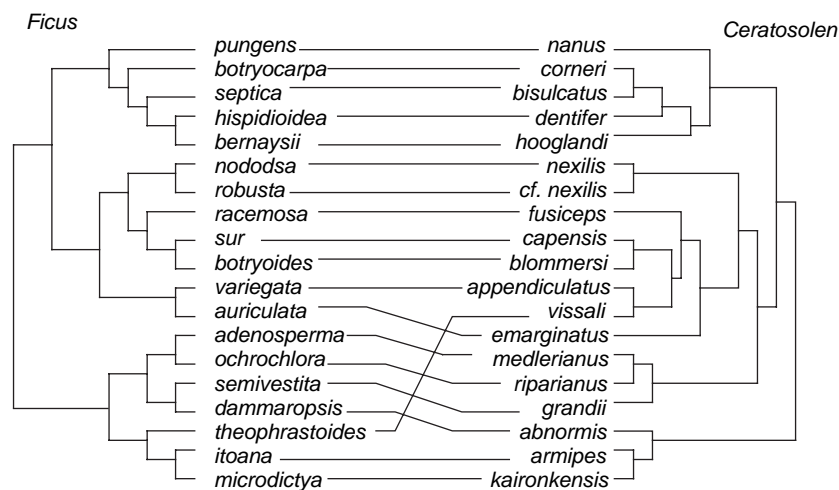

Fig. 17. Evidence for co-speciation between figs (*Ficus*, left) and their pollinating fig wasps (*Ceratosolen*), mostly from Melanesia. The phylogeny of host and symbiont are near mirror-images of each other. This co-speciation suggests that interspecific interactions can enhance diversity. Redrawn from Weiblen & Bush (2002), with kind permission of Blackwell Publishing.

male-male competition. Such systems hold the potential to set up an evolutionary arms race between male and female morphology or behaviour and hence cause rapid evolution that may enhance the probability of speciation. In support of such ideas, Arnqvist *et al.* (2000) found a positive association between polyandry and species richness across sister clades.

Koh *et al.* (2003) found that highly sexually dichromatic species of butterfly in Singapore were only half as likely to go extinct as other species. This is the opposite pattern to that expected, since sexual selection can act antagonistically with natural selection, hence hindering individual survival, and it may also reduce effective population size by skewing reproductive success in the sexually selected sex. The reason for the curious result may be because dichromatism covaries with another trait that makes such species less likely to go extinct, or the result may simply be spurious because of inadequate control of phylogenetic effects.

(c) Tropical distribution

Because it is a general phenomenon that taxa are more species rich in tropical regions (Willig, Kaufman & Stevens, 2003; Hillebrand, 2004), it is almost a pre-requisite that species-rich taxa have largely tropical distributions. The classical negative latitudinal species richness gradient is indeed well documented in a number of insect groups such as ants (Cushman, Lawton & Manly, 1993), beetles (Lobo, 2000), grasshoppers (Davidowitz & Rosenzweig, 1998) and butterflies (Kocher & Williams, 2000).

Exceptions to the negative pattern have however also been documented in several insect taxa (Gaston & Blackburn, 2000). At least some of the non-significant relationships are probably due to lack of statistical power (Hillebrand, 2004). However, several of the observed patterns with modes at intermediate latitudes may be genuinely valid at the global scale (e.g. ichneumonids, aphids, bumblebees, sawflies). An important question is whether the negative species richness

gradient is generally tighter or more extreme in insects than in other taxa. In a qualitative review, Willig *et al.* (2003) showed that terrestrial invertebrates as a whole display a high proportion of “modal” relationships (peaks at intermediate latitude) especially at large spatial scales, compared to other taxonomic or functional groups. It would be exciting to see if this difference is statistically significant in a formal meta-analysis: if it is, the species richness of insects will be all the more remarkable.

Hillebrand (2004) conducted a formal meta-analysis of 581 latitudinal gradients of which 79 were of insects. Unfortunately this analysis did not include taxonomic group *per se* as an explanatory variable, but did investigate other variables that are characteristic of insects such as body size, terrestriality, ectothermy, flight, and species richness. In general, larger bodied organisms displayed tighter and more negative slopes, thermoregulation and dispersal type had no significant main effect, whilst species-rich groups had more negative slopes. All this does, unfortunately, not enable us to state whether gradients are different in insects compared to other groups because insects have small body sizes, tending to decrease their species richness gradient, but high species richness, tending to increase it.

Allen, Brown & Gillooly (2002) report a general quantitative relationship between temperature and species richness across a number of ectothermic organisms, but whether insects conform to this pattern is presently unknown. Willig *et al.* (2003) report that the beta diversity (spatial turnover of species) increases towards the tropics in a number of taxa, though insects are not yet amongst those shown to display this trend.

If insect species richness gradients do turn out to be unusual relative to those in other taxa, further studies can then investigate the proximate evolutionary basis for this. Cardillo (1999) confirmed for swallowtail butterflies that there was a (negative) relationship between latitude and the net rate of cladogenesis (Table 5). Alternative cladogenetic possibilities might be that the ancestors of higher insect taxa

have more commonly originated at particular latitudes, or that they more commonly shift range towards particular latitudes (see Böhm & Mayhew, 2005; Mayhew, 2006). These possibilities remain to be investigated in insect taxa and more generally.

(d) *Generation time and rates of increase*

With the exception of body size, surprisingly few insect life-history traits have been investigated in relation to their effects on cladogenetic processes. Misof (2002) studied the effect of voltinism (the number of generations per year) on species richness in Anisoptera (Odonata) but found no significant effect (Table 5). Voltinism however was significant in predicting recent range changes of bees and hoverflies in Britain and the Netherlands (Biesmeijer *et al.*, 2006), with multi-voltine species showing smaller declines (Table 4). Another study of relevance is that of Katzourakis *et al.* (2001), which looked at the effect of ovariole number in predicting species richness in hoverflies. Ovariole number may be related to fecundity. However, this variable was not a significant predictor of species richness (Table 5).

(e) *Population size and density*

We would expect the risk of extinction to be low for large population sizes or densities. Interestingly, a variety of relationships are observed in nature (Table 4), including positive relationships to extinction risk (Didham *et al.*, 1998; Kotiaho *et al.*, 2005), non-significant relationships (Kruess & Tscharntke, 2000; K. F. Davies *et al.*, 2004; Shahabuddin & Ponte, 2005), and negative relationships (Kruess & Tscharntke, 1994; Davies *et al.*, 2000). Whilst negative relationships are intuitive, and non-significant relationships are to be expected in studies where there are many other potential explanatory variables, the positive relationships require some explanation. The association may be related to dispersal ability, with less dispersive species building up higher local population sizes, whilst contributing to a small number of subpopulations making them vulnerable to extinction.

(f) *Adaptability*

Zeh *et al.* (1989) used sister-taxon comparisons to compare the diversity of oviposition sites in a clade with species richness, and found a positive association. If the diversity of oviposition sites can be taken as an indication of the adaptability of a clade, this provides support for the hypothesis that adaptability increases species richness. Labandeira's (1997) study of the evolution of insect mouthparts shows that mouthpart diversity generally increased as did family-level diversity, but that mouthpart diversity increases tended to pre-date taxonomic diversity increases (Fig. 5). Nonetheless, the origins of certain well-defined taxa and candidate radiations, such as that of the Holometabola, were accompanied by increases in the number of mouthpart types. Again, if mouthpart diversity represents adaptability, this suggests a role for adaptability in controlling diversity. It

is obviously possible to expand greatly on the range of traits which are included in adaptability analyses. There has been considerable discussion on how such tests might best be performed in a botanical context, relating both to the value of phylogenetically based analyses, as well as what the appropriate null model might be to best detect an association between evolutionary flexibility and species richness (see Ricklefs & Renner, 2000). It would be worthwhile if future studies on insects built upon this experience.

Discussions of adaptability might include those that address key innovations that by implication are functionally involved in adaptability. Candidates include complete metamorphosis, wing folding, sensory and neurosophistication, and even such features as sexual selection and specialization.

(4) **Relative influence**

We have evidence for thirteen of the fourteen ultimate hypotheses for insect species richness. This suggests that many traits and processes have contributed and furthermore that we know broadly what those traits and processes are. These are worthwhile achievements, but do not in themselves provide us with a satisfying answer to the title question. It is probably true of all organisms that many traits and processes have had significant effects on species richness. The special issue with insects is the magnitude of the species richness, and therefore, for each of the possible contributing traits and processes, we should ideally also address the magnitude of their effects.

For sister-taxon comparisons (Table 5), the data consist of the species richnesses of each pair. The simplest test that can be performed on these data is a sign test (Mitter *et al.*, 1988; Zeh *et al.*, 1989; Wiegmann *et al.*, 1993; Farrell, 1998), which outlines the significance and consistency of the sign of the effect, but which ignores the quantitative differences between sister taxa. To get a feel for relative effect size, it is useful to calculate the average difference in species richness in each test. Some quantitative species richness comparisons (*sensu* Cardillo, 1999) are given in Table 5. To calculate the exact effect on species richness of the trait would mean including all possible comparisons in such a study, and in most cases such studies are rather incomplete in this sense. The accuracy of the estimated contrasts varies from study to study: for example, swallowtail butterflies (e.g. Cardillo, 1999) have been extremely well described, but the richness of phytophagous insect groups and other very large clades may be underdescribed by orders of magnitude (Gaston, 1991). A rough guess at the effect on species richness is attempted in Table 5, based on how widespread the trait is likely to be and on how diversifying its effect. Novel oviposition sites, phytophagy and sexual conflict are likely to have accounted for very large numbers of species, confirming that these traits not only have relatively robust effects across studies, but also that their effects are of great magnitude.

Similarly, the relative strength of statistical coefficients can in principle be used to compare effect size in studies of the correlates of current extinction risk, though the authors

of these studies do not always report them or do not always conduct tests that allow the comparison between variables to be made. Benedick *et al.* (2006) conclude that host-plant specificity is more important than body size or geographic range. Koh *et al.* (2004) report that host-plant and habitat specialization were the most important determinants of extinction risk. Shahabuddin & Ponte (2005) found that body size was more important than rarity or wing loading. Nieminen (1996) found that extinction risk of moths was more affected by their host plant characteristics than the characteristics of the moths themselves, supporting a role for ecological ultimate variables over morphological ones. Sullivan *et al.* (2000) found that flight period, possibly indicating dispersal ability, was the most consistent predictor of red data book status in European hoverflies. The most influential variable in Finnish noctuid moths depends on the measure of extinction risk used (Mattila *et al.*, 2006). When it is geographic range size, flight period length is the most influential. When it is distribution change, overwintering stage is the most influential. As can be seen, these findings are heterogeneous, and point to case-specificity in the influence of different variables.

The question of the relative effect size of unique (morphological) key innovations is in one way simpler than that of repeatedly evolved characters simply because we do not need to estimate how many times the character has evolved. However, there is some added complexity: to determine the magnitude of the shift in diversification, sister-taxon comparisons are not enough: the rate of diversification of the ancestor of the clade must be known or estimated. This could in principle be done by any number of means, such as maximum likelihood (Sanderson & Donoghue, 1994), or some more simple method (T. J. Davies *et al.* 2004). Mayhew (2003) used parsimony algorithms to estimate such shifts across the ordinal tree, and then used the shift in rate to estimate species richness in the absence of the shift. The largest shifts in rate mostly coincide with the origins of orders. The Coleoptera and Diptera head the list respectively. Of higher taxa, the Eumetabola, Paraneoptera, Pterygota and Holometabola coincide with fairly large shifts. The effects on species richness are highest in the Eumetabola and Pterygota respectively (they are more ancient shifts), whilst Coleoptera and Holometabola are in the top ten. The magnitudes of these effects are very large indeed, despite often equivocal findings on the significance of their effects on rates.

(5) Combining and distinguishing ultimate variables

A variety of ultimate hypotheses have some statistical support. This suggests that, to use statistical terminology, that there may be several “main effects” that explain insect species richness. But since so many tests of ultimate hypotheses only address a single explanatory variable (e.g. Table 5), we are right to ask if some factors would remain significant once other factors are controlled for. Studies that address several explanatory variables sometimes do not go as far as reporting such results (Didham *et al.*, 1998; Katzourakis *et al.*, 2001; Kotiaho *et al.*, 2005; Biesmeijer

et al., 2006): sometimes, but probably not always, the data may not make this feasible. Others however have employed appropriate statistical controls (Nieminen, 1996; Davies *et al.*, 2000; Kruess & Tschardtke, 2000; Sullivan *et al.*, 2000; Misof, 2002; Kotze & O’Hara, 2003; K. F. Davies *et al.*, 2004; Koh *et al.*, 2004; Shahabuddin & Ponte, 2005; Benedick *et al.*, 2006). In the case of unique key innovations, studies that control for trickling down are appropriate to control for the effects of other key innovations (Mayhew, 2002, *cf.* Zeh *et al.*, 1989).

These studies suggest that some potential explanatory variables are intercorrelated: for example Shahabuddin & Ponte (2005) found that wing loading and body size both affected extinction risk in tropical butterflies, but that the effects of wing loading disappeared in a multivariate analysis. Of the ultimate variables listed in Table 1, several associations are possible: body size might be related to generation times and rates of increase, degree of specialization, trophic level (hence phytophagy), tropical distribution, sensory and neurosophistication, and dispersal ability. For the same reason, all the possible pairwise combinations of these variables may also be associated. Functionally, complete metamorphosis might enable greater segmental/appendage or mouthpart diversity, dietary specialization, the attainment of different trophic levels, and even high rates of increase. Folding wings are obviously only possible if wings are present. There is clearly therefore a need for future studies to think carefully about controlling for other potential explanatory variables, because ultimately we want not just to provide support for some hypotheses, but also to rule out others where possible.

There may additionally be interactions between explanatory variables; where the effect of one variable is contingent on another (de Queiroz, 2002). Some studies of historic or current extinction risk have looked for and found such interactions. K. F. Davies *et al.* (2004) found that specialized beetle species were more likely to decline as a result of habitat fragmentation if they naturally occurred at low densities. Kotze & O’Hara (2003) found that a number of interactions explained ground beetle declines in the low countries; for example specialization was more likely to cause decline in brachypterous or macropterous species than wing dimorphic species.

Whilst interesting in these specific cases, the taxonomic scope of these studies limits their applicability as overall explanatory variables of insect extinction risk. It would be very interesting to look for such interactions in a wide-scale study of extinction risk or of species richness across the insects. Several of the ultimate hypotheses listed in Table 1 are obviously nested in some sense: for example, it is rather difficult to imagine flight evolving without sensory or neurosophistication; likewise the diversifying effect of phytophagy (or other trophic niches) may have been dependent on flight, wing folding or complete metamorphosis, or mouthpart diversity, or innovations of the egg or ovipositor. A brief look at the richness and relationships of the different taxonomic groups of insects (Fig. 10) is enough to suggest a high degree of contingency in insect evolution, and such tests should be a priority for the future.

(6) Linking proximate and ultimate variables

(a) *From proximate to ultimate*

Section III suggests that the proximate factors most likely to be responsible for the species richness of the insects, relative to other non-insect taxa, are low extinction rate and high carrying capacity. It is then simple to ask which of the ultimate variables, for which there is supporting evidence, are likely to affect these two proximate variables. Ideally these should be general properties of insects. High population density and small body size are general properties of insects that may help to reduce extinction risk (Sections III.2*h* and III.3*d*). High dispersal propensity, assisted by flight, is also a plausible candidate with some support (Section III.2*b*). Whilst it can be argued that phytophagy is a less universal characteristic of insects than any of the above, it is still a very significant feature and is likely to have helped reduce extinction risk as well as promoting sustained diversification (Section III.3*a*). This diversification, as well as that of non-phytophagous insects, is intuitively likely to have been facilitated by mouthpart innovations (and other characteristics facilitating adaptability), folding wings, and complete metamorphosis. Note however that the evidence for a macroevolutionary effect of these variables is less strong.

(b) *From ultimate to proximate*

Ultimate studies have provided strong evidence for a role for interspecific interactions, particularly phytophagy, combined with specialization, sexual selection and sexual conflict, plus at least one morphological key innovation at supra-ordinal level, probably flight, wing folding or complete metamorphosis. By what proximate route have these factors exerted their effects?

The link between polyandry and species richness is likely to be due to increased speciation rates rather than reduced extinction rates, or due to any effect on carrying capacity, and is likely to be exerted through increased sexual conflict between males and females leading to rapid evolution of reproductive isolation. Indeed, polyandry was chosen as a surrogate for sexual conflict itself, and the study was motivated by theoretical and empirical studies suggesting that sexual conflict might provide an effective route to speciation (see Arnqvist *et al.*, 2000). Furthermore, since sexual conflict is likely to hinder the reproductive performance of other individuals of a species, it is likely to increase extinction rates. A very similar explanation may serve for sexual selection. The link between proximate and ultimate processes thus comes here from other studies of a more mechanistic nature. But can macroevolutionary studies themselves outline specific links?

In fossil studies it is possible to study originations and extinction explicitly, though it may not be so easy to link them to a given explanatory variable. Yang (2001) showed that net rates of family diversification were consistently higher in Holometabola than Paraneoptera, though extinction rates were not different in the Holometabola and Hemimetabola. This suggests that the Holometabola have higher origination rates, and hence implies that complete

metamorphosis has raised speciation rates (though see Section III.2*d*, Mayhew, 2002).

What about studies on extant species? The origin of wings may have increased net rates of diversification, and studies on current extinction risk suggest that part of the reason at least might be lower rates of extinction. Studies have so far not supported a role for body size in net rates of cladogenesis, but studies of current extinction risk tend to support the idea that extinction rates are higher in large taxa. This suggests that the reason for the right-skewed body size distribution in insects is due to extinction rather than speciation rates. One study linking trophic level to current extinction risk supports the idea that the species richness of phytophages is partly due to lowered extinction rates rather than just higher speciation rates, whilst high current extinction risk in habitat or host plant specialists suggests that any effect of increased specialization in increasing species richness, if it is found, is likely to be due to speciation rather than extinction. Co-speciation studies also suggest that interspecific interactions can directly enhance speciation rates. The single study so far addressing sexual selection effects on current extinction risk shows that they are negatively correlated. This suggests that the association between sexual selection and species richness might not just be due to enhanced speciation rates.

(c) *Reconciling the different approaches*

Proximate studies suggest that the reason for the species richness of insects is low extinction rates and sustained diversification due to a high carrying capacity. Further investigation suggests that small body size, high population density, dispersal (through flight) and possibly phytophagy are likely reasons for low extinction rates, whilst a range of morphological key innovations combining with phytophagy may have promoted sustained diversification. Ultimate studies suggest that phytophagy, sexual selection and sexual conflict, and one or more major morphological key innovations are likely to have promoted diversity by sustained rates of diversification and high speciation rates. Clearly, whilst there is some useful consensus here, there are also some apparent discrepancies. In particular, proximate studies point to low extinction rates but several ultimate studies to high speciation rates. How can we reconcile these different results?

One useful perspective is to remember that proximate studies largely compare insect with non-insect taxa and therefore attempt to understand why insects rather than other taxa have diversified so much. The ultimate answers to this are quite satisfying because although small body size and high population density are commonplace amongst other animal taxa, the combination of those and flight and phytophagy is unique to insects. But what about the ultimate studies of sexual selection and sexual conflict and complete metamorphosis that invoke high speciation rates? These take comparisons within the insects as their source of data and therefore address why some insects have diversified much more than others. The differences between these insect groups is probably due to different speciation rates, and this need not imply that they have high speciation

rates relative to non-insect taxa. Speciation rates do not need to be very high given the age of many of the innovations in question. Take for example, the large phytophagous beetle radiations mentioned above. These have higher net rates of diversification than their sister taxa (Farrell, 1998), but these rates are still modest because the taxa are quite ancient. Increasing speciation rates only a little within this context could allow net rates of cladogenesis and speciation rates to remain modest, whilst having a great effect on species richness.

IV. FUTURE WORK

Using the hypotheses listed in Table 1, and the methods mentioned in Section III, it is possible to outline a number of potential hypothesis tests that have yet to be carried out. In addition there are a number of ongoing issues of data and analytical methods or practice for future researchers to improve upon. I concentrate on areas in which practical advance is possible in the near future.

(1) New tests

(a) Proximate variables

The greatest scope for rapid improvement in knowledge here probably comes from studies of extant taxa. New estimates of phylogeny at the species level for a range of taxa hold the opportunity to estimate both speciation and extinction rates, and to test whether they have changed over time. At present only a limited number of such studies has been conducted, but today such phylogenies can be produced and analysed relatively easily. A particular challenge would be to generate a species-level phylogeny for a species-rich or ancient group where the potential for limits to species richness is greater and might be detected. Pleistocene fossils and red data books offer tantalizing evidence for low extinction risks in insects, but the generality of findings to date has rightly been questioned. A concerted effort to improve our knowledge of extinction risk in certain well-chosen insect taxa would allow more effective comparisons to be made with other groups. Likewise, improving our knowledge of Pleistocene fossils in a wide variety of geographic locations would allow the generality of previous studies to be assessed.

(b) Ultimate variables

I suggest two types of study that could make an immediate impact. The first is to test for more potential key innovations using the family-level fossil record. Yang's (2001) study relating to origination and extinction rates in the Holometabola *versus* Hemimetabola could be complemented by similar such studies on the Neoptera *versus* Palaeoptera (for wing folding as a key innovation), Paleoptera *versus* Apterygota (for wings as a key innovation), and Entognatha *versus* Apterygota (for the insect body ground plan as a key innovation).

The other series of tests relate to comparative studies on species richness and evolutionary flexibility, resulting from

mouthpart diversity, appendage diversity, segmental morphological diversity, behavioural (or sensory) diversity, and to ecological generalization. Precedents for such studies already exist either in other taxa (Ricklefs & Renner 2000), or using relevant data within the insects but applied to a different question (Beccaloni & Symons, 2000; Nosil & Mooers, 2005). Such studies would serve to fill what is presently a gaping hole in our portfolio of relevant empirical studies.

(2) New data

(a) Phylogeny

For progress on the role of unique key innovations, it is essential that the ordinal-level phylogeny of the hexapods be more resolved. Whilst it is clear that not all key innovations occurred at taxonomic levels higher than orders, clearly one or more did. Areas lacking consensus include the relationships of the entognathan orders (see also Carapelli *et al.*, 2000; Giribet *et al.*, 2004; Regier, Shultz & Kambic, 2004), of the palaeopteran orders (Hovmöller *et al.*, 2002), of several of the polyneopteran orders (Flook & Rowell, 1998; Terry & Whiting, 2005), the paraneopteran orders (see Murrell & Barker, 2005; Jost & Shaw, 2006), the neuropteroid orders (Haring & Aspöck, 2004), the position of the Strepsiptera (Whiting, 2002; Kukulova Peck & Lawrence, 2004), or Zoraptera (Yoshizawa & Johnson, 2005). In addition some recent studies have suggested, contrary to the above consensus that the Hexapoda may not be monophyletic (Nardi *et al.*, 2003; Giribet *et al.*, 2004; Pisani, 2004), and that the Thysanura and Archaeognatha may form a monophyletic group (Regier *et al.*, 2004).

In addition, previous work has highlighted that the Diptera and Coleoptera may contain unique key innovations, and therefore phylogenies of these two orders, initially at family level, would be useful (e.g. Caterino *et al.*, 2002; Yeates, Meier & Wiegmann, 2003). At some stage it would be useful to combine the existing phylogenetic information for higher taxa of insects into a single comprehensive picture, such as in a supertree, and prospects are good for this.

(b) Fossil data

The fossil record for insect families now needs updating. The most up-to-date dataset at the time of writing is Jarzembowski & Ross (1996), which itself updates Ross & Jarzembowski (1993). However, between 1983 and 1995, approximately 500 new families and 1000 new genera of insects were recorded (Ross *et al.*, 2000). Carpenter (1992) provides genus-level data but only contains information published up to 1983, and thus is very out-of-date. In addition, it only gives low temporal definition (epochs). The last comprehensive species-level dataset was Handlirsch (1906-08), thus now a century old.

An updated family record will help to provide a more comprehensive picture of diversity change and origination and extinction rates. In addition it is likely to improve the dating of phylogenies generally by providing evidence of robust dates and of new first fossils for less well-preserved taxa.

(c) Extant species richness

The number of insect species on earth is not known (Stork, 1988; Gaston, 1991; May, 1992; Ødegaard, 2000), nor, amazingly, is the number of described species because (i) there is no single complete catalogue of described species, (ii) the number of newly described species each year is very large (>6,000), and the level of synonymy is also very high amongst these (Gaston, 1991). Nonetheless, estimates by experts of the number of described species do show a relatively high degree of correspondence (Table 2).

Can we reliably estimate the total number of species for each major taxon? There is no substitute for alpha taxonomy, but this is likely to produce slow improvements in results. A medium-term alternative might be to try and make some broad estimates of asymptotic species richness using established extrapolation techniques. A number of methods are available to do this (see O'Brien & Wibmer, 1979; Palmer, 1990; Colwell & Coddington, 1994; Hammond, 1994; Williams & Gaston, 1994; Dolphin & Quicke, 2001). This will undoubtedly be a time-consuming process, but is not beyond the means of a dedicated army of researchers, and some progress has already been made (see Bartlett *et al.*, 1999; Dolphin & Quicke, 2001). However, for some taxa, such as Coleoptera, extrapolation *via* some common techniques may not yet be reliably performed because the accumulation curve of species has not yet begun to asymptote strongly (Gaston, 1991). It would however be interesting to see how results changed from applying a single multiplication to all orders. Experience suggests that this would increase the power of some tests to detect significant changes in cladogenesis.

(d) Current extinction risk

The vast majority of studies on insect extinction risk refer to local studies on the effects of habitat fragmentation (Table 4). It would be valuable to have more data on global-scale threat status for a variety of taxonomic groups to understand the characteristics associated with extinction risk. Again, this would require a targeted and concerted effort. To complement such studies, it would be useful to have species-level phylogenies so that comprehensive phylogeny-based analyses can be accommodated.

V. CONCLUSIONS

(1) Fossil and phylogenetic data have provided tests of all the major (18) macroevolutionary hypotheses commonly posed to explain the species richness of insects.

(2) Despite this progress, a firm understanding of the reasons for insect species richness remains elusive. This is not simply because some of the above hypotheses have not been extensively tested. Several other problems stand in our way, including: interpreting conflicting messages from different sources of data; rating the importance of different hypotheses that are statistically supported; linking specific

proximate to specific ultimate explanations and *vice versa*; and understanding how different ultimate hypotheses might combine, overlap or explain each other.

(3) I have suggested some tentative solutions to the above problems, including (i) some suggestions on the merits and drawbacks of different studies; (ii) distinguishing between tests for “why insects are more species rich than non-insect taxa” and tests for “why some groups of insects are more species rich than others”; (iii) attempting to quantify the effects of different key innovations on extant species richness, rather than just testing for significance; (iv) applying tests for ultimate variables to different proximate variables and comparing their results; and (v) employing tests for interactions between variables or “contingent evolution”.

(4) With the provisos mentioned in (2) above, I tentatively suggest that:

(i) the data generally support sustained moderate to low rates of cladogenesis, in the general absence of logistic feedback, combined with low extinction rates, as the proximate explanation for insect (as opposed to non-insect) species richness.

(ii) That the ultimate factors most likely responsible for low extinction rates are small body size, high population density, high dispersal propensity through flight, and phytophagy.

(iii) The ultimate factors most likely responsible for sustained diversification are phytophagy, small size, sensory sophistication, mouthpart diversification, flight, wing folding and complete metamorphosis. However, specific macroevolutionary evidence linking these to high clade carrying capacities is absent.

(iv) Within the insects, species richness has been promoted by interactions with plants, coevolutionary interactions in general at least in a mechanistic sense, sexual selection and sexual conflict. There is more equivocal evidence for a link to flight or dispersal ability, complete metamorphosis and possibly other unique key innovations. However, the deep imbalance of the hexapod evolutionary tree suggests strongly that one or more unique key innovations have strongly shaped the species richness of the group. Many of these variables are likely to have acted through increasing rates of speciation, though only relative to other insects.

(5) We can obtain firmer answers to our broad question through several routes. There is still enormous scope for testing existing hypotheses with existing data. There are ongoing issues of data improvement which need to be addressed. New analytical methods are possible to improve our understanding of existing data.

VI. ACKNOWLEDGEMENTS

I thank L. Lester whose (2005) comment in *Antenna* persuaded me that this article was really needed, Folmer Bokma for correspondence on his method, and comments from Rob Davis, Matthew Mills, Chris Thomas and an anonymous referee.

VII. REFERENCES

- AGAPOW, P. M. & ISAAC, N. J. B. (2002). MacroCAIC: revealing correlates of species richness by comparative analysis. *Diversity and Distributions* **8**, 41–43.
- ALLEN, A. P., BROWN, J. H. & GILLOOLY, J. F. (2002). Global biodiversity, biochemical kinetics, and the energetic-equivalence rule. *Science* **297**, 1545–1548.
- ARNQVIST, G., EDVARDSSON, M., FRIBERG, U. & NILSSON, T. (2000). Sexual conflict promotes speciation in insects. *Proceedings of the National Academy of Sciences, USA* **97**, 10460–10464.
- BARRACLOUGH, T. G., BARCLAY, M. V. L. & VOGLER, A. P. (1998). Species richness: Does flower power explain beetle-mania? *Current Biology* **8**, R843–R845.
- BARRACLOUGH, T. G. & VOGLER, A. P. (2002). Recent diversification rates in North American tiger beetles estimated from a dated mtDNA phylogenetic tree. *Molecular Biology and Evolution* **19**, 1706–1716.
- BARTLETT, R., PICKERING, J., GAULD, I., & WINDSOR, D. (1999). Estimating global biodiversity: tropical beetles and wasps send different signals. *Ecological Entomology* **24**, 118–121.
- BECCALONI, G. W. & SYMONS, F. B. (2000). Variation of butterfly diet breadth in relation to host-plant predictability: results from two faunas. *Oikos* **90**, 50–66.
- BENEDICK, S., HILL, J. K., MUSTAFFA, N., CHEY, V. K., MARYATI, M., SEARLE, J. B., SCHUILTHUIZEN, M. & HAMER, K. C. (2006). Impacts of rain forest fragmentation on butterflies in northern Borneo: species richness, turnover, and the value of small fragments. *Journal of Applied Ecology* **43**, 967–977.
- BENTON, M. J. (1995). Diversification and extinction in the history of life. *Science* **268**, 52–58.
- BENTON, M. J. (1997). Models for the diversification of life. *Trends in Ecology and Evolution* **12**, 490–495.
- BENTON, M. J. (2001). Biodiversity on land and in the sea. *Geological Journal* **36**, 211–230.
- BIJMEIJER, J. C., ROBERTS, S. P. M., REEMER, M., OHLEMÜLLER, R., EDWARDS, M., PEETERS, T., SCHAFFERS, A. P., POTTS, S. G., KLEUKERS, R., THOMAS, C. D., SETTELE, J. & KUNIN, W. E. (2006). Parallel declines in pollinator and insect-pollinated plants in Britain and the Netherlands. *Science* **313**, 351–354.
- BÖHM, M. & MAYHEW, P. J. (2005). Historical biogeography and the evolution of the latitudinal gradient of species richness in the Papionini (Primate: Cercopithecidae). *Biological Journal of the Linnean Society* **85**, 235–246.
- BOKMA, F. (2003). Testing for equal rates of cladogenesis in diverse taxa. *Evolution* **57**, 2469–2474.
- BOUDREAUX, H. B. (1979). *Arthropod Phylogeny with Special Reference to Insects*. Wiley, New York.
- CARAPPELLI, A., FRATI, F., NARDI, F., DALLAI, R. & SIMON, C. (2000). Molecular phylogeny of the apterygotan insects based on nuclear and mitochondrial genes. *Pedobiologia* **44**, 361–373.
- CARDILLO, M. (1999). Latitude and rates of diversification in birds and butterflies. *Proceedings of the Royal Society of London, Series B* **266**, 1221–1225.
- CARPENTER, F. M. (1953). The geologic history and evolution of insects. *American Scientist* **41**, 256–270.
- CARPENTER, F. M. (1992). *Treatise on Invertebrate Paleontology*, Part R of *Arthropoda, Superclass Hexapoda*. Geological Society of America, Boulder, Colorado; University of Kansas, Lawrence.
- CATERINO, M. S., SHULL, V. L., HAMMOND, P. M., & VOGLER, A. P. (2002). The basal phylogeny of the Coleoptera inferred from 18S rDNA sequences. *Zoologica Scripta* **31**, 41–49.
- COLWELL, R. K. & CODDINGTON, J. A. (1994). Estimating terrestrial biodiversity through extrapolation. *Philosophical Transactions of the Royal Society of London, Series B* **345**, 101–118.
- CONNOR, E. F. & TAVERNER, M. P. (1997). The evolution and adaptive significance of the leaf-mining habit. *Oikos* **79**, 6–25.
- COOPE, G. R. (1994). The response of insect faunas to glacial-interglacial climatic fluctuations. *Philosophical Transactions of the Royal Society of London, Series B* **344**, 19–26.
- COOPE, G. R. (1995). Insect faunas in ice age environments: why so little extinction? In *Extinction Rates* (eds J. H. Lawton & R. M. May), pp. 55–74. Oxford University Press, Oxford.
- COYNE, J. A. & ORR, H. A. (2004). *Speciation*. Sinauer, Sunderland MA.
- CUSHMAN, J. H., LAWTON, J. H. & MANLY, B. F. J. (1993). Latitudinal patterns in European ant assemblages: variation in species richness and body size. *Oecologia* **95**, 30–37.
- DAVIDOWITZ, D. & ROSENZWEIG, M. L. (1998). The latitudinal gradient of species diversity among North American grasshoppers (Acrididae) within a single habitat: a test of the spatial heterogeneity hypothesis. *Journal of Biogeography* **25**, 553–560.
- DAVIES, K. F., MARGULES, C. R. & LAWRENCE, J. F. (2000). Which traits of species predict population declines in experimental forest fragments? *Ecology* **81**, 1450–1461.
- DAVIES, K. F., MARGULES, C. R. & LAWRENCE, J. F. (2004). A synergistic effect puts rare, specialized species at greater risk of extinction. *Ecology* **85**, 265–271.
- DAVIES, T. J., BARRACLOUGH, T. G., CHASE, M. W., SOLTIS, P. S., SOLTIS, D. E. & SAVOLAINEN, V. (2004). Darwin's abominable mystery: Insights from a supertree of the angiosperms. *Proceedings of the National Academy of Sciences, USA* **101**, 1904–1909.
- DE QUEIROZ, A. (1998). Interpreting sister-group tests of key innovation hypotheses. *Systematic Biology* **47**, 710–718.
- DE QUEIROZ, A. (1999). Do image-forming eyes promote evolutionary diversification? *Evolution* **53**, 1654–1664.
- DE QUEIROZ, A. (2002). Contingent predictability in evolution: Key traits and diversification. *Systematic Biology* **51**, 917–929.
- DIDHAM, R. H., HAMMOND, P. M., LAWTON, J. H., EGGLETON, P. & STORK, N. E. (1998). Beetle responses to tropical forest fragmentation. *Ecological Monographs* **68**, 295–323.
- DOLPHIN, K. & QUICKE, D. L. J. (2001). Estimating the global species richness of an incompletely described taxon: an example using parasitoid wasps (Hymenoptera: Braconidae). *Biological Journal of the Linnean Society* **73**, 279–286.
- DUNN, R. R. (2005). Modern insect extinctions, the neglected majority. *Conservation Biology* **19**, 1030–1036.
- EBLE, G. J. (1999). Originations: land and sea compared. *Geobios* **32**, 223–234.
- ELZINGA, R. J. (2004). *Fundamentals of Entomology*, 6th Edn. Pearson/Prentice Hall, Upper Saddle River, NJ.
- ENGEL, M. S. & GRIMALDI, D. A. (2004). New light shed on the oldest insect. *Nature* **427**, 627–630.
- EVANS, H. E. (1984). *Insect Biology*. Addison-Wesley, Reading, Massachusetts.
- FAGAN, W. F., MEIR, E., PRENDEGAST, J., FOLARIN, A., & KARIEVA, P. (2001). Characterizing population vulnerability for 758 species. *Ecology Letters* **4**, 132–138.
- FARRELL, B. D. (1998). “Inordinate fondness” explained: why are there so many beetles? *Science* **281**, 555–559.
- FAYERS, S. R. & TREWIN, N. H. (2005). A hexapod from the Early Devonian Windyfield chert, Rhynie, Scotland. *Palaeontology* **48**, 1117–1130.

- FLOOK, P. K. & ROWELL, C. H. F. (1998). Inferences about orthopteroid phylogeny and molecular evolution from small subunit nuclear ribosomal DNA sequences. *Insect Molecular Biology* **7**, 163–178.
- GARDEZI, T. & DA SILVA, J. (1999). Diversity in relation to body size in mammals: A comparative study. *American Naturalist* **153**, 110–123.
- GASTON, K. J. (1991). The magnitude of global insect species richness. *Conservation Biology* **5**, 283–296.
- GASTON, K. J. & BLACKBURN, T. M. (2000). *Pattern and Process in Macroecology*. Blackwell: Oxford.
- GAUNT, M. W. & MILES, M. A. (2002). An insect molecular clock dates the origin of the insects and accords with palaeontological and biogeographic landmarks. *Molecular Biology and Evolution* **19**, 748–761.
- GIRIBET, G., EDGEcombe, G. D., CARPENTER, J. M., D'HAESE, C. A. & WHEELER, W. C. (2004). Is Ellipura monophyletic? A combined analysis of basal hexapod relationships with emphasis on the origin of insects. *Organisms, Diversity and Evolution* **4**, 319–340.
- GLENNER, H., THOMSEN, P. F., HEBGAARD, M. B., SØRENSEN, M. V. & WILLERSLEV, E. (2006). The origin of insects. *Science* **314**, 1883–1884.
- GRIMALDI, D. & ENGEL, M. S. (2005). *Evolution of the Insects*. Cambridge University Press, Cambridge.
- GULLAN, P. J. & CRANSTON, P. S. (2005). *The Insects: an Outline of Entomology*, 3rd edn. Blackwell, Oxford.
- GUYER, C. & SLOWINSKI, J. B. (1991). Comparisons of observed phylogenetic topologies with null expectations among three monophyletic lineages. *Evolution* **45**, 340–350.
- GUYER, C. & SLOWINSKI, J. B. (1993). Adaptive radiation and the topology of large phylogenies. *Evolution* **47**, 253–263.
- HAMBLER, C. & SPEIGHT, M. R. (1996). Extinction rates in British nonmarine invertebrates since 1900. *Conservation Biology* **10**, 892–896.
- HAMMOND, P. M. (1994). Practical approaches to the estimation of the extent of biodiversity in speciose groups. *Philosophical Transactions of the Royal Society of London, Series B* **345**, 119–136.
- HANDELSRICH, A. (1906–1908). *Die Fossilen Insekten und die Phylogenie der Rezenten Formen*. Engelmann, Leipzig.
- HARING, E. & ASPOCK, U. (2004). Phylogeny of the Neuropterida: a first molecular approach. *Systematic Entomology* **29**, 415–430.
- HARVEY, P. H., MAY, R. M. & NEE, S. (1994). Phylogenies without fossils. *Evolution* **48**, 523–529.
- HENNIG, W. (1981). *Insect Phylogeny*. John Wiley, Chichester.
- HEY, J. (1992). Using phylogenetic trees to study speciation and extinction. *Evolution* **46**, 627–640.
- HILLEBRAND, H. (2004). On the generality of the latitudinal diversity gradient. *American Naturalist* **163**, 192–211.
- HORN, D. J. (1976). *Biology of Insects*. W. B. Saunders Co, Philadelphia.
- HOVMÖLLER, R., PAPE, T. & KALLERSJO, M. (2002). The Palaeoptera problem: Basal pterygote phylogeny inferred from 18S and 28S rDNA sequences. *Cladistics* **18**, 313–323.
- IMMS, A. D. (1947). *Insect Natural History*. Collins, London.
- ISAAC, N. J. B., AGAPOW, P. M., HARVEY, P. H. & PURVIS, A. (2003). Phylogenetically nested comparisons for testing correlates of species richness: A simulation study of continuous variables. *Evolution* **57**, 18–26.
- JACKSON, A. P. (2004). Cophylogeny of the *Ficus* microcosm. *Biological Reviews* **79**, 751–768.
- JANZ, N. & NYLIN, S. (1998). Butterflies and plants: A phylogenetic study. *Evolution* **52**, 486–502.
- JARZEMBOWSKI, E. A. & ROSS, A. J. (1996). Insect origination and extinction in the Phanerozoic. In *Biotic Recovery from Mass Extinction Events, Geological Society Special Publication No. 102* (ed. M. B. Hart), pp. 65–78. Geological Society of London, London.
- JOHNSON, K. P. & CLAYTON, D. H. (2003). Coevolutionary history of ecological replicates: comparing phylogenies of wing and body lice to columbiform hosts. In: *Tangled Trees: Phylogeny, Cospeciation and Coevolution* (Ed. R. D. M. Page), pp. 262–286. University of Chicago Press, Chicago.
- JOST, M. C. & SHAW, K. L. (2006). Phylogeny of Ensifera (Hexapoda: Orthoptera) using three ribosomal loci, with implications for the evolution of acoustic communication. *Molecular Phylogenetics and Evolution* **38**, 510–530.
- KATZOURAKIS, A., PURVIS, A., AZMEH, S., ROTHERAY, G. & GILBERT, F. (2001). Macroevolution of hoverflies (Diptera: Syrphidae): the effect of using higher-level taxa in studies of biodiversity, and correlates of species richness. *Journal of Evolutionary Biology* **14**, 219–227.
- KOCHER, S. D. & WILLIAMS, E. H. (2000). The diversity and abundance of North American butterflies vary with habitat disturbance and geography. *Journal of Biogeography* **27**, 785–794.
- KOH, L. P., SODHI, N. S. & BROOK, B. W. (2004). Ecological correlates of extinction proneness in tropical butterflies. *Conservation Biology* **18**, 1571–1578.
- KORKEAMÄKI, E. & SUHONEN, J. (2002). Distribution and habitat specialization of species affect local extinction in dragonfly Odonata populations. *Ecography* **25**, 459–465.
- KOTIAHO, J. S., KAITALA, V., KOMONEN, A. & PÄIVINEN, J. (2005). Predicting the risk of extinction from shared ecological characteristics. *Proceedings of the National Academy of Sciences, USA* **102**, 1963–1967.
- KOTZE, D. J. & O'HARA, R. B. (2003). Species decline – but why? Explanations of carabid beetle (Coleoptera, Carabidae) declines in Europe. *Oecologia* **135**, 138–148.
- KRAUSS, J., STEFFAN-DEWENTER, I. & TSCHARNTKE, T. (2003). Local species immigration, extinction, and turnover of butterflies in relation to habitat area and habitat isolation. *Oecologia* **137**, 591–602.
- KRUSS, A. & TSCHARNTKE, T. (1994). Habitat fragmentation, species loss, and biological control. *Science* **264**, 1581–1584.
- KRUSS, A. & TSCHARNTKE, T. (2000). Species richness and parasitism in a fragmented landscape: experiments and field studies with insects on *Vicia sepium*. *Oecologia* **122**, 129–137.
- KUKALOVA-PECK, J. & LAWRENCE, J. F. (2004). Relationships among coleopteran suborders and major endoneopteran lineages: Evidence from hind wing characters. *European Journal of Entomology* **101**, 95–144.
- LABANDEIRA, C. C. (1997). Insect mouthparts: Ascertaining the paleobiology of insect feeding strategies. *Annual Review of Ecology and Systematics* **28**, 153–193.
- LABANDEIRA, C. C. & SEPKOSKI, J. J. JR. (1993). Insect diversity in the fossil record. *Science* **261**, 310–315.
- LOBO, J. M. (2000). Species diversity and composition of dung beetle (Coleoptera: Scarabaeoidea) assemblages in North America. *Canadian Entomologist* **132**, 307–321.
- MATTHEWS, J. V. JR. (1980). Tertiary land bridges and their climate: backdrop for the development of the present Canadian insect fauna. *Canadian Entomologist* **112**, 1089–1103.

- MATTILA, N., KAITALA, V., KOMONEN, A., KOTIAHO, J. S. & PÄIVINENE, J. (2006). Ecological determinants of distribution decline and risk of extinction in moths. *Conservation Biology* **20**, 1161–1168.
- MAWDSLEY, N. A. & STORK, N. E. (1995). Species extinctions in insects: ecological and biogeographic considerations. In *Insects in a Changing Environment* (eds R. Harrington & N. E. Stork), pp. 321–369. Academic Press, London.
- MAY, R. M. (1978). The dynamics and diversity of insect faunas. In *Diversity of Insect Faunas* (eds L. A. Mound & N. Waloff), pp. 188–204. Blackwell, Oxford.
- MAY, R. M. (1992). How many species inhabit the Earth? *Scientific American* **267**, 42–48.
- MAYHEW, P. J. (2002). Shifts in hexapod diversification and what Haldane could have said. *Proceedings of the Royal Society of London, Series B* **269**, 969–974.
- MAYHEW, P. J. (2003). A tale of two analyses: estimating the consequences of shifts in hexapod diversification. *Biological Journal of the Linnean Society* **80**, 23–36.
- MAYHEW, P. J. (2006). *Discovering Evolutionary Ecology: Bringing together Ecology and Evolution*. Oxford University Press, Oxford.
- MCGAVIN, G. C. (2001). *Essential Entomology: an Order by Order Introduction*. Oxford University Press, Oxford.
- MISOE, B. (2002). Diversity of Anisoptera (Odonata): Inferring speciation processes from patterns of morphological diversity. *Zoology* **105**, 355–365.
- MITTER, C., FARRELL, B. & WIEGMANN, B. (1988). The phylogenetic study of adaptive zones – has phytophagy promoted insect diversification? *American Naturalist* **132**, 107–128.
- MOOERS, A. Ø. & HEARD, S. B. (1997). Inferring evolutionary process from phylogenetic tree shape. *Quarterly Review of Biology* **72**, 31–54.
- MOORE, B. R., CHAN, K. M. A. & DONOGHUE, M. J. (2004). Detecting diversification rate variation in supertrees. In *Phylogenetic Supertrees: Combining Information to Reveal the Tree of Life* (ed. O. R. P. Bininda-Emonds), pp. 487–533. Kluwer Academic, Dordrecht.
- MURRELL, A. & BARKER, S. C. (2005). Multiple origins of parasitism in lice: phylogenetic analysis of SSU rDNA indicates that the Phthiraptera and Psocoptera are not monophyletic. *Parasitology Research* **97**, 274–280.
- NARDI, F., SPINSANTI, G., BOORE, J. L., CARAPPELLI, A., DALLAI, R. & FRATI, F. (2003). Hexapod origins: Monophyletic or paraphyletic? *Science* **299**, 1887–1889.
- NEE, S. (2001). Inferring speciation rates from phylogenies. *Evolution* **55**, 661–668.
- NEE, S., BARRACLOUGH, T. G. & HARVEY, P. H. (1996). Temporal changes in biodiversity: detecting patterns and identifying causes. In *Biodiversity: A Biology of Numbers and Difference* (ed. K. J. Gaston), pp. 230–252. Oxford University Press, Oxford.
- NEE, S., MAY, R. M. & HARVEY, P. H. (1994). The reconstructed evolutionary process. *Philosophical Transactions of the Royal Society of London, Series B*, **344**, 305–311.
- NEE, S., MOOERS, A. Ø. & HARVEY, P. H. (1992). Tempo and mode of evolution revealed from molecular phylogenies. *Proceedings of the National Academy of Sciences, USA* **98**, 8322–8326.
- NIEMINEN, M. (1996). Risk of extinction in moths: effect of host plant characteristics. *Oikos* **76**, 475–484.
- NOSIL, P. & MOOERS, A. Ø. (2005). Testing hypotheses about ecological specialization using phylogenetic trees. *Evolution* **59**, 2256–2263.
- O'BRIEN, C. W. & WIBMER, G. J. (1979). The use of trend curves of rates of species descriptions: examples from the Curculionidae (Coleoptera). *The Coleopterists' Bulletin* **33**, 151–166.
- ØDEGAARDE, F. (2000). How many species of arthropods? Erwin's estimate revised. *Biological Journal of the Linnean Society* **71**, 583–597.
- ORME, C. D. L., ISAAC, N. J. B. & PURVIS, A. (2002). Are most species small? Not within species-level phylogenies. *Proceedings of the Royal Society of London, Series B* **269**, 1279–1287.
- PALMER, M. W. (1990). The estimation of species richness by extrapolation. *Ecology* **71**, 1195–1198.
- PARKER, S. P. (1982). *Synopsis and Classification of Living Organisms*. McGraw-Hill, New York.
- PISANI, D. (2004). Identifying and removing fast-evolving sites using compatibility analysis: An example from the Arthropoda. *Systematic Biology* **53**, 978–989.
- PISANI, D., POLING, L. L., LYONS-WEILER, M., & HEDGES, S. B. (2004). The colonization of land by animals: molecular phylogeny and divergence times among arthropods. *BMC Biology* **2**, 1.
- PURVIS, A. (1996). Using interspecies phylogenies to test macro-evolutionary hypotheses. In *New Uses for New Phylogenies* (eds P. H. Harvey, A. J. Leigh Brown, J. Maynard Smith & S. Nee), pp. 153–168. Oxford University Press, Oxford.
- RAUP, D. M. (1985). Mathematical models of cladogenesis. *Paleobiology* **11**, 42–52.
- RAUP, D. M., GOULD, S. J., SCHOPF, T. J. M. & SIMBERLOFF, D. S. (1973). Stochastic models of phylogeny and the evolution of diversity. *Journal of Geology* **81**, 525–542.
- REGIER, J. C., SHULTZ, J. W. & KAMBIC, R. E. (2004). Phylogeny of basal hexapod lineages and estimates of divergence times. *Annals of the Entomological Society of America* **97**, 411–419.
- RESH, V. H. & CARDÉ, R. T. (eds.) (2003). *Encyclopedia of Insects*. Academic Press, San Diego.
- RIBERA, I., BARRACLOUGH, T. G. & VOGLER, A. P. (2001). The effect of habitat type on speciation rates and range movements in aquatic beetles: inferences from species-level phylogenies. *Molecular Ecology* **10**, 721–735.
- RICKLEFS, R. E. & RENNER, S. S. (2000). Evolutionary flexibility and flowering plant familial diversity: a comment on Dodd, Silvertown and Chase. *Evolution* **54**, 1061–1065.
- ROMOSER, W. S. (1973). *The Science of Entomology*. Macmillan, New York.
- ROSS, A. J. & JARZEMBOWSKI, E. A. (1993). Arthropoda (Hexapoda; Insecta). In *The Fossil Record 2*, (ed. M. J. Benton), pp. 363–426. Chapman & Hall, London.
- ROSS, A. J., JARZEMBOWSKI, E. A. & BROOKS, S. J. (2000). The Cretaceous and Cenozoic record of insects (Hexapoda) with regard to global change. In *Biotic Response to Global Change: The Last 145 Million Years* (eds S. J. Culver & P. F. Rawson), pp. 288–302. The Natural History Museum, London; Cambridge University Press, Cambridge.
- ROSS, A. J. & YORK, P. V. (2004). A catalogue of the type and figured specimens of Hexapoda from the Rhynie Chert (early Devonian) at The Natural History Museum, London, UK. *Transactions of the Royal Society of Edinburgh: Earth Sciences* **94**, 391–395.
- SAMWAYS, M. J. (2005). *Insect Diversity Conservation*. Cambridge University Press, Cambridge.
- SANDERSON, M. J. & DONOGHUE, M. J. (1994). Shifts in diversification rate with the origin of the angiosperms. *Science* **264**, 1590–1593.

- SAVOLAINEN, V., HEARD, S. B., POWELL, M. P., DAVIES, T. J. & MOOERS, A. Ø. (2002). Is cladogenesis heritable? *Systematic Biology* **51**, 835–843.
- SEPKOSKI, J. J. (1998). Rates of speciation in the fossil record. *Philosophical Transactions of the Royal Society of London, Series B* **353**, 315–326.
- SHAHABUDDIN, G. & PONTE, C. A. (2005). Frugivorous butterfly species in tropical forest fragments: correlates of vulnerability to extinction. *Biodiversity and Conservation* **14**, 1137–1152.
- SPEIGHT, M. R., WATT, A. & HUNTER, M. (1999). *Ecology of Insects: Concepts and Applications*. Blackwell Science, Oxford.
- STANLEY, S. M. (1979). *Macroevolution: Pattern and Process*. Freeman, San Francisco.
- STORK, N. E. (1988). Insect diversity: facts, fiction and speculation. *Biological Journal of the Linnean Society* **35**, 321–337.
- SULLIVAN, M. S., GILBERT, F., ROTHERAY, G., CROASDALE, S., & JONES, M. (2000). Comparative analyses of correlates of Red data book status: a case study using European hoverflies (Diptera: Syrphidae). *Animal Conservation* **3**, 91–95.
- TERRY, M. D. & WHITING, M. F. (2005). Mantophasmatodea and phylogeny of the lower neopterous insects. *Cladistics* **21**, 240–257.
- THOMAS, C. D. (2000). Dispersal and extinction in fragmented landscapes. *Proceedings of the Royal Society of London, Series B* **267**, 139–145.
- THOMAS, C. D., CAMERON, A., GREEN, R. E., BAKKENES, M., BEAUMONT, L. J., COLLINGHAM, Y. C., ERASMUS, B. F. N., DE SIQUEIRA, M. F., GRAINGER, A., HANNAH, L., HUGHES, L., HUNTLEY, B., VAN JAARSVELD, A. S., MIDGLEY, G. F., MILES, L., ORTEGA-HUERTA, M. A., PETERSON, A. T., PHILLIPS, O. L. & WILLIAMS, S. E. (2004). Extinction risk from climate change. *Nature* **427**, 145–148.
- THOMAS, J. A. & MORRIS, M. G. (1995). Patterns, mechanisms and rates of extinction among invertebrates in the United Kingdom. *Philosophical Transactions of the Royal Society of London, Series B* **344**, 47–54.
- THOMAS, J. A., TELFER, M. G., ROY, D. B., PRESTON, C. D., GREENWOOD, J. J. D., ASHER, J., FOX, R., CLARKE, R. T. & LAWTON, J. H. (2004). Comparative losses of British butterflies, birds, and plants and the global extinction crisis. *Science* **303**, 1879–1881.
- THOMPSON, J. N. (1987). Symbiont induced speciation. *Biological Journal of the Linnean Society* **32**, 385–393.
- TSCHARNTKE, T., STEFFAN-DEWENTER, I., KRUESS, A. & THIES, C. (2002). Characteristics of insect populations on habitat fragments: A mini review. *Ecological Research* **17**, 229–239.
- WEIBLEN, G. D. & BUSH, G. L. (2002). Speciation in fig pollinators and parasites. *Molecular Ecology* **11**, 1573–1578.
- WHALLEY, P. & JARZEMBOWSKI, E. A. (1981). A new assessment of *Rhyniella*, the earliest known insect, from the Devonian of Rhynie, Scotland. *Nature* **291**, 317.
- WHEELER, Q. D. (1990). Insect diversity and cladistic constraints. *Annals of the Entomological Society of America* **83**, 1031–1047.
- WHEELER, W. C., WHITING, M., WHEELER, Q. D. & CARPENTER, J. M. (2001). The phylogeny of the extant hexapod orders. *Cladistics* **17**, 113–169.
- WHITING, M. F. (2002). Phylogeny of the holometabolous insect orders: molecular evidence. *Zoologica Scripta* **31**, 3–15.
- WIEGMANN, B. M., MITTER, C. & FARRELL, B. (1993). Diversification of carnivorous parasitic insects – extraordinary radiation of specialized dead-end? *American Naturalist* **142**, 737–754.
- WILLIAMS, P. H. & GASTON, K. J. (1994). Measuring more of biodiversity: can higher-taxon richness predict wholesale species richness? *Biological Conservation* **67**, 211–217.
- WILLIG, M. R., KAUFMAN, D. M. & STEVENS, R. D. (2003). Latitudinal gradients of biodiversity: Pattern, process, scale, and synthesis. *Annual Review of Ecology and Systematics* **34**, 273–309.
- WILLIS, J. C. (1922). *Age and Area*. Cambridge University Press, Cambridge.
- WILLS, M. A., BRIGGS, D. E. G. & FORTEY, R. A. (1994). Disparity as an evolutionary index: a comparison of Cambrian and Recent Arthropods. *Paleobiology* **20**, 93–130.
- WILSON, M. V. H. (1983). Is there a characteristic rate of radiation for the insects? *Paleobiology* **9**, 79–85.
- YANG, A. S. (2001). Modularity, evolvability, and adaptive radiations: a comparison of the hemi- and holometabolous insects. *Evolution & Development* **3**, 59–72.
- YEATES, D. K., MEIER, R. & WIEGMANN, B. M. (2003). Phylogeny of true flies (Diptera): A 250 million year old success story in terrestrial diversification. *Entomologische Abhandlungen* **61**, 119–173.
- YOSHIZAWA, K. & JOHNSON, K. P. (2005). Aligned 18S for Zoraptera (Insecta): Phylogenetic position and molecular evolution. *Molecular Phylogenetics and Evolution* **37**, 572–580.
- YULE, G. U. (1924). A mathematical theory of evolution, based on the conclusions of Dr J. C. Willis, F.R.S. *Philosophical Transactions of the Royal Society of London, Series B*, **213**, 21–87.
- ZEH, D. W., ZEH, J. A. & SMITH, R. L. (1989). Ovipositors, amnions and eggshell architecture in the diversification of terrestrial arthropods. *Quarterly Review of Biology* **64**, 147–168.